



This is a digital copy of a book that was preserved for generations on library shelves before it was carefully scanned by Google as part of a project to make the world's books discoverable online.

It has survived long enough for the copyright to expire and the book to enter the public domain. A public domain book is one that was never subject to copyright or whose legal copyright term has expired. Whether a book is in the public domain may vary country to country. Public domain books are our gateways to the past, representing a wealth of history, culture and knowledge that's often difficult to discover.

Marks, notations and other marginalia present in the original volume will appear in this file - a reminder of this book's long journey from the publisher to a library and finally to you.

### **Usage guidelines**

Google is proud to partner with libraries to digitize public domain materials and make them widely accessible. Public domain books belong to the public and we are merely their custodians. Nevertheless, this work is expensive, so in order to keep providing this resource, we have taken steps to prevent abuse by commercial parties, including placing technical restrictions on automated querying.

We also ask that you:

- + *Make non-commercial use of the files* We designed Google Book Search for use by individuals, and we request that you use these files for personal, non-commercial purposes.
- + *Refrain from automated querying* Do not send automated queries of any sort to Google's system: If you are conducting research on machine translation, optical character recognition or other areas where access to a large amount of text is helpful, please contact us. We encourage the use of public domain materials for these purposes and may be able to help.
- + *Maintain attribution* The Google "watermark" you see on each file is essential for informing people about this project and helping them find additional materials through Google Book Search. Please do not remove it.
- + *Keep it legal* Whatever your use, remember that you are responsible for ensuring that what you are doing is legal. Do not assume that just because we believe a book is in the public domain for users in the United States, that the work is also in the public domain for users in other countries. Whether a book is still in copyright varies from country to country, and we can't offer guidance on whether any specific use of any specific book is allowed. Please do not assume that a book's appearance in Google Book Search means it can be used in any manner anywhere in the world. Copyright infringement liability can be quite severe.

### **About Google Book Search**

Google's mission is to organize the world's information and to make it universally accessible and useful. Google Book Search helps readers discover the world's books while helping authors and publishers reach new audiences. You can search through the full text of this book on the web at <http://books.google.com/>

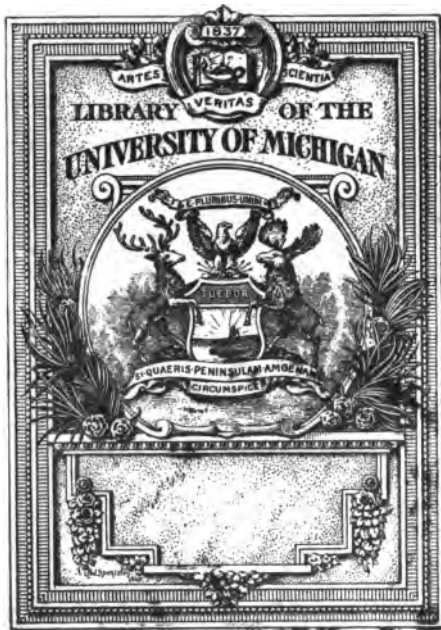

CHEM. LIB.

TT

515

.W339

1911

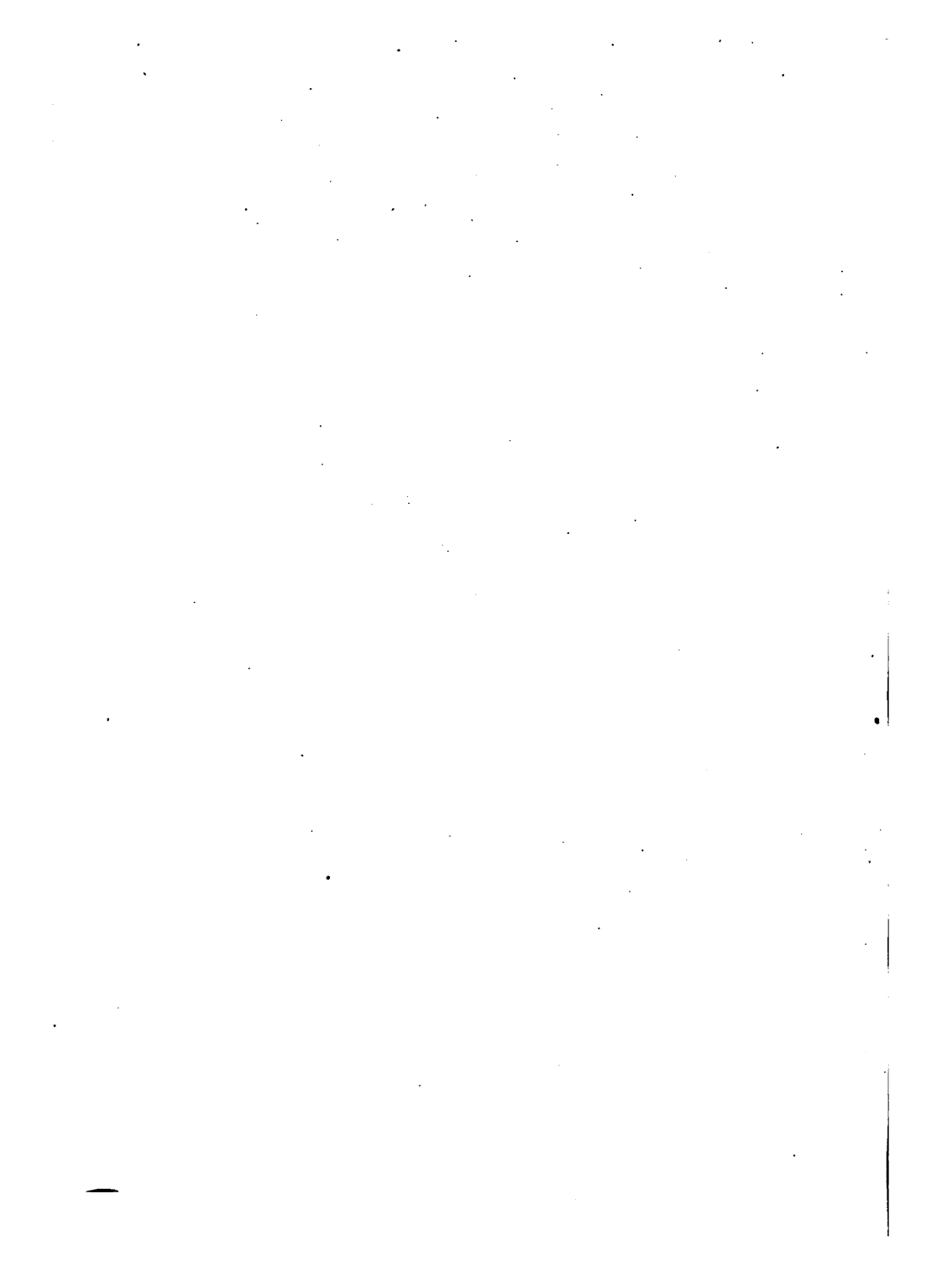





LEWIS INSTITUTE, CHICAGO

# THE LIBRARY OF HOME ECONOMICS

A COMPLETE HOME-STUDY COURSE

ON THE NEW PROFESSION OF HOME-MAKING AND ART OF RIGHT LIVING;  
THE PRACTICAL APPLICATION OF THE MOST RECENT ADVANCES  
IN THE ARTS AND SCIENCES TO HOME AND HEALTH

PREPARED BY TEACHERS OF  
RECOGNIZED AUTHORITY

FOR HOME-MAKERS, MOTHERS, TEACHERS, PHYSICIANS, NURSES,  
DIETITIANS, PROFESSIONAL HOUSE MANAGERS, AND ALL INTERESTED  
IN HOME, HEALTH, ECONOMY AND CHILDREN

TWELVE VOLUMES

NEARLY THREE THOUSAND PAGES, ONE THOUSAND ILLUSTRATIONS  
TESTED BY USE IN CORRESPONDENCE INSTRUCTION  
REVISED AND SUPPLEMENTED



CHICAGO  
AMERICAN SCHOOL OF HOME ECONOMICS  
1911

**COPYRIGHT, 1907**

**BY**

**HOME ECONOMICS ASSOCIATION**

**Entered at Stationers' Hall, London**

*All Rights Reserved*



## AUTHORS

### ISABEL BEVIER, Ph. M.

Professor of Household Science, University of Illinois. Author U. S. Government Bulletins, "Development of the Home Economics Movement," "Selection and Preparation of Food," etc. President American Home Economics Association.

### ALICE PELOUBET NORTON, M. A.

Assistant Professor of Home Economics, School of Education, University of Chicago; Director of the Chautauqua School of Domestic Science; Author "Teaching of Home Economics."

### S. MARIA ELLIOTT

Instructor in Home Economics, Simmons College; Formerly Instructor School of Housekeeping, Boston.

### ANNA BARROWS

Teacher of Cookery, Teachers' College, Columbia University; Director Chautauqua School of Cookery; formerly Editor "American Kitchen Magazine"; Author "Home Science Cook Book."

### ALFRED CLEVELAND COTTON, A. M., M. D.

Professor Diseases of Children, Rush Medical College, University of Chicago; Visiting Physician Presbyterian Hospital, Chicago; Author of "Diseases of Children."

### BERTHA M. TERRILL, A. B.

Professor of Home Economics and Dean of Women, University of Vermont; Author of U. S. Government Bulletins.

### KATE HEINTZ WATSON

Formerly Instructor in Domestic Economy, Lewis Institute; Lecturer University of Chicago.

### MARION FOSTER WASHBURNE

Editor "The Mothers' Magazine;" Lecturer Chicago Froebel Association; Author "Everyday Essays," "Family Secrets," etc.

### MARGARET E. DODD

Graduate Massachusetts Institute of Technology; Teacher of Science, Woodward Institute.

### AMY ELIZABETH POPE

With the Panama Canal Commission; Formerly Instructor in Practical and Theoretical Nursing, Training School for Nurses, Presbyterian Hospital, New York City.

### MAURICE LE BOSQUET, S. B.

Director American School of Home Economics; Member American Public Health Association and American Chemical Society.

## CONTRIBUTORS AND EDITORS

### ELLEN H. RICHARDS

Author "Cost of Food," "Cost of Living," "Cost of Shelter,"  
"Food Materials and Their Adulteration," etc., etc.; Chair-  
man Lake Placid Conference on Home Economics.

### MARY HINMAN ABEL

Author of U. S. Government Bulletins, "Practical Sanitary  
and Economic Cooking," "Safe Food," etc.

### THOMAS D. WOOD, M. D.

Professor of Physical Education, Columbia University.

### H. M. LUFKIN, M. D.

Professor of Physical Diagnosis and Clinical Medicine, Uni-  
versity of Minnesota.

### OTTO FOLIN, Ph. D.

Special Investigator, McLean Hospital, Waverly, Mass.

### T. MITCHELL PRUDDEN, M. D., LL. D.

Author "Dust and Its Dangers," "The Story of the Bac-  
teria," "Drinking Water and Ice Supplies," etc.

### FRANK CHOUTEAU BROWN

Architect, Boston, Mass.; Author of "The Five Orders of  
Architecture," "Letters and Lettering."

### MRS. MELVIL DEWEY

Secretary Lake Placid Conference on Home Economics.

### HELEN LOUISE JOHNSON

Professor of Home Economics, James Millikan University,  
Decatur.

### FRANK W. ALLIN, M. D.

Instructor Rush Medical College, University of Chicago.

---

## MANAGING EDITOR

### MAURICE LE BOSQUET, S. B.

Director American School of Home Economics.

**BOARD OF TRUSTEES**  
**OF THE AMERICAN SCHOOL OF HOME ECONOMICS**

---

**MRS. ARTHUR COURTENAY NEVILLE**

President of the Board.

**MISS MARIA PARLOA**

Founder of the first Cooking School in Boston; Author of "Home Economics," "Young Housekeeper," U. S. Government Bulletins, etc.

**MRS. MARY HINMAN ABEL**

Co-worker in the "New England Kitchen," and the "Rumford Food Laboratory;" Author of U. S. Government Bulletins, "Practical Sanitary and Economic Cooking," etc.

**MISS ALICE RAVENHILL**

Special Commissioner sent by the British Government to report on the Schools of Home Economics in the United States; Fellow of the Royal Sanitary Institute, London.

**MRS. ELLEN M. HENROTIN**

Honorary President General Federation of Woman's Clubs.

**MRS. FREDERIC W. SCHOFF**

President National Congress of Mothers.

**MRS. LINDA HULL LARNED**

Past President National Household Economics Association; Author of "Hostess of To-day."

**MRS. WALTER McNAB MILLER**

Chairman of the Pure Food Committee of the General Federation of Woman's Clubs.

**MRS. J. A. KIMBERLY**

Vice President of National Household Economics Association.

**MRS. JOHN HOODLESS**

Government Superintendent of Domestic Science for the province of Ontario; Founder Ontario Normal School of Domestic Science, now the MacDonal Institute.



DRESS MAKING IN MEXICO

# Textiles and Clothing

BY

**KATE HEINTZ WATSON**

GRADUATE ARMOUR INSTITUTE OF TECHNOLOGY

FORMERLY INSTRUCTOR IN DOMESTIC ART

LEWIS INSTITUTE

LECTURER UNIVERSITY OF CHICAGO



CHICAGO

AMERICAN SCHOOL OF HOME ECONOMICS

1911

COPYRIGHT 1906, 1907, 1910, BY  
HOME ECONOMICS ASSOCIATION

---

Entered at Stationers Hall, London  
*All Rights Reserved*

Q 21 S 12 RR

## CONTENTS

---

PRIMITIVE METHODS . . . . .	3
WEAVING . . . . .	14
FIBERS . . . . .	29
COTTON . . . . .	29
WOOL . . . . .	37
FLAX . . . . .	43
SILK . . . . .	53
MODERN METHODS . . . . .	59
WEAVING . . . . .	69
WEAVES . . . . .	72
BLEACHING AND DYEING . . . . .	78
PRINTING . . . . .	81
FINISHING . . . . .	83
COTTON GOODS . . . . .	85
LINENS . . . . .	86
WOOLENS AND WORSTEDS . . . . .	88
SILKS . . . . .	90
NAMES OF FABRICS . . . . .	94
BIBLIOGRAPHY ON TEXTILES . . . . .	103
HAND SEWING . . . . .	107
ORNAMENTAL STITCHES . . . . .	114
HEMS . . . . .	123
TUCKS AND SEAMS . . . . .	128
PLACKETS . . . . .	135
SEWING ON BANDS . . . . .	138
FASTENINGS . . . . .	141
PATCHING . . . . .	149
DARNING . . . . .	155
MITERING EMBROIDERY, JOINING LACE . . . . .	158
MACHINE SEWING . . . . .	162

21119

DRESSMAKING . . . . .	167
PATTERNS . . . . .	171
MAKING SEVEN-GORED SKIRT . . . . .	172
MAKING SHIRT WAISTS . . . . .	182
LINED WAIST . . . . .	186
SLEEVES . . . . .	194
COLLARS . . . . .	198
SEAMLESS YOKES . . . . .	200
PRESSING . . . . .	201
CONSTRUCTION AND ORNAMENT IN DRESS . . . . .	203
ORNAMENT OF TEXTILES . . . . .	212
COLOR . . . . .	214
CHILDREN'S CLOTHES . . . . .	216
CARE OF CLOTHING . . . . .	219
CLEANING . . . . .	221
REPAIRING . . . . .	225
BIBLIOGRAPHY ON SEWING AND DRESSMAKING . . . . .	229
REFERENCES: HISTORY OF COSTUME; ORNAMENT AND DESIGN . . . . .	234
PROGRAM FOR SUPPLEMENTAL STUDY . . . . .	236
INDEX . . . . .	241



11111



**"THE THREAD OF LIFE"**  
Spinning with the Distaff and Spindle. From a Painting.

1107

## TEXTILES AND CLOTHING

---

**S** PINNING and weaving are among the earliest arts. In the twisting of fibers, hairs, grasses, and sinews by rolling them between the thumb and fingers, palms of the hands, or palms and naked thigh, we have the original of the spinning wheel and the steam-driven cotton spindle; in the roughest plaiting we have the first hint of the finest woven cloth. The need of securing things or otherwise strengthening them then led to binding, fastening, and sewing. The wattle-work hut with its roof of interlaced boughs, the skins sewn by fine needles with entrails or sinews, the matted twigs, grasses, and rushes are all the crude beginnings of an art which tells of the settled life of to-day.

Nothing is definitely known of the origin of these arts; all is conjecture. They doubtless had their beginning long before mention is made of them in history, but these crafts—spinning and weaving—modified and complicated by inventions and, in modern times transferred largely from man to machine, were distinctively woman's employment.

The very primitive type of spinning, where no spindle was used, was to fasten the strands of goats' hair or wool to a stone which was twirled round until

**Origin  
of Textile  
Arts**

**Primitive  
Methods**



**ITALIAN WOMAN SPINNING FLAX**  
Spindle and Distaff.

From Hull House Museum. (In This Series of Pictures the Spinners and Weavers Are in Native Costume.)



**RUSSIAN SPINNING**  
Flax Held on Frame, Leaving Both Hands Free to Manage the  
Thread and Spindle.  
From Hull House Museum.

the yarn was sufficiently twisted when it was wound upon the stone and the process repeated over and over.

**Spinning  
with the  
Spindle**

The next method of twisting yarn was with the spindle, a straight stick eight to twelve inches long on which the thread was wound after twisting. At first it had a cleft or split in the top in which the thread was fixed; later a hook of bone was added to the upper end. The spindle is yet used by the North American Indians, the Italians, and in the Orient. The bunch of wool or flax fibers is held in the left hand; with the right hand the fibers are drawn out several inches and the end fastened securely in the slit or hook on the top of the spindle. A whirling motion is given to the spindle on the thigh or any convenient part of the body; the spindle is then dropped, twisting the yarn, which is wound on the upper part of the spindle. Another bunch of fibers is drawn out, the spindle is given another twirl, the yarn is wound on the spindle, and so on.

**Spindle  
Whorl**

A spindle containing a quantity of yarn was found to rotate more easily, steadily and continue longer than an empty one, hence the next improvement was the addition of a *whorl* at the bottom of the spindle. These whorls are discs of wood, stone, clay, or metal which keep the spindle steady and promote its rotation. The process in effect is precisely the same as the spinning done by our grandmothers, only the spinning wheel did the twisting and reduced the time required for the operation.



**SPINNING WITH CRUDE WHEEL AND DISTAFF**  
Distaff Thrust Into the Belt.

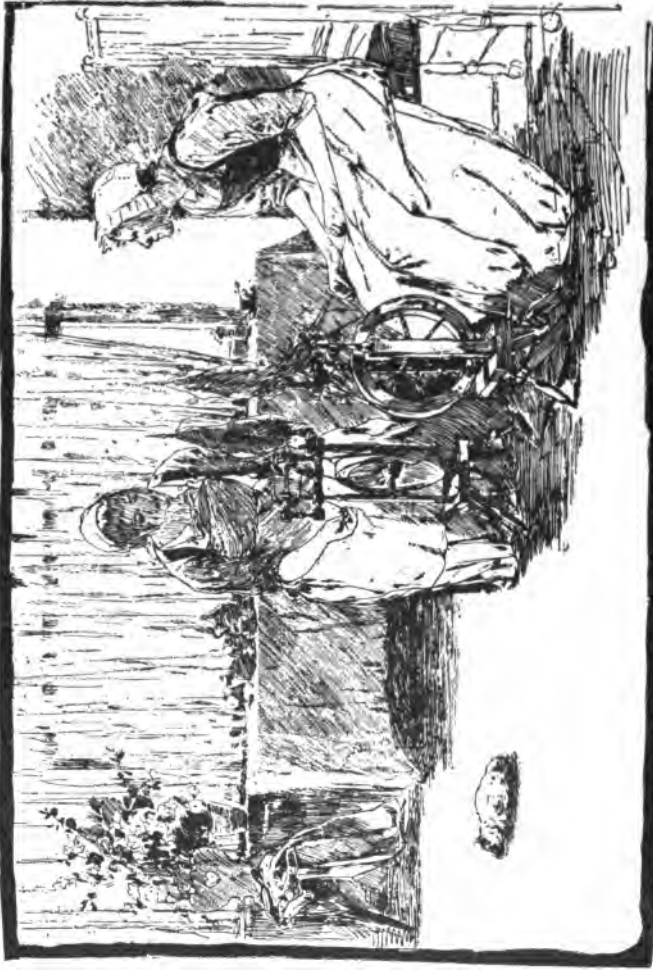

"GOSSIP" IN THE OLDEN TIMES





**COLONIAL WOOL WHEEL**  
The Large Wheel Revolved by Hand Thus Turning the Spindle and Twisting the Yarn,  
Which Is Then Wound on the Spindle; Intermittent in Action.



**COLONIAL FLAX WHEEL**

Worked by a Foot Treadle; Distaff on the Frame of the Wheel;  
"Fliers" on the Spindle, Continuous in Action; Capacity  
Seven Times That of Hand Spindle.



**DUTCH WHEEL**

Spinner Sits in Front of the Wheel—Spinning Flax at Hull House.





**SYRIAN SPINNING**

**Spinner Sits on the Floor, Wheel Turned by a Crank; Spindle Held in Place by Two Mutton Joints Which Contain Enough Oil for Lubrication. At Hull House.**

century and was a great improvement upon the distaff and spindle. This it will be seen was a comparatively modern invention. The rude wheel used by the natives of Japan and India may have been the progenitor of the European wheel, as about this time intercourse between the East and Europe increased. These wheels were used for spinning flax, wool, and afterwards cotton, until Hargreaves' invention superseded it.

#### WEAVING

Someone has said that "weaving is the climax of textile industry." It is an art practiced by all savage



PUEBLO WOMAN WORKING HEDDLE IN WEAVING A BELT

tribes and doubtless was known before the dawn of history. The art is but a development of mat-making and basketry, using threads formed or made by spinning in place of coarser filaments.

In the beginning of the art the warp threads were stretched between convenient objects on the ground



**A NAVAJO BELT WEAVER**



ZUNI WOMAN WEAVING CEREMONIAL BELT



or from horizontal supports. At first the woof or filling threads were woven back and forth between the warp threads as in darning. An improvement was the device called the "heald" or "heddle," by means of which alternate warp threads could be drawn away from the others, making an opening through which the filling thread could be passed quickly. One form

The  
Heddle

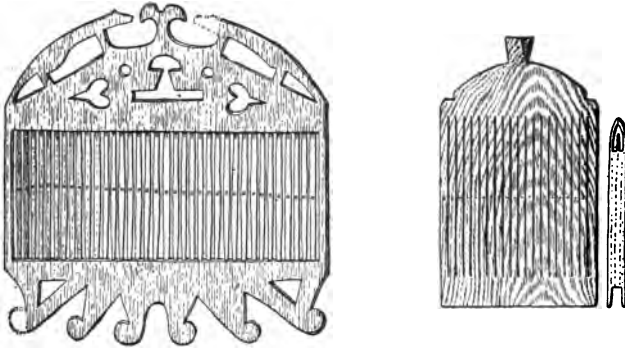

PRIMITIVE HEDDLES

of the heddle was simply a straight stick having loops of cord or sinew through which certain of the warp threads were run. Another form was a slotted frame having openings or "eyes" in the slats. This was carved from one piece of wood or other material or made from many. Alternate warp threads passed through the eyes and the slots. By raising or lowering the heddle frame, an opening was formed through which the filling thread, wound on a rude shuttle, was thrown. The next movement of the heddle frame



**NAVAJO LOOM**  
One of the Earliest Types of Looms. At Hull House.

crossed the threads over the filling and made a new opening for the return of the shuttle. At first the filling thread was wound on a stick making a primitive bobbin. Later the shuttle to hold the bobbin was devised.



**SIMPLE COLONIAL LOOM**

Before the "reed" was invented, the filling threads were drawn evenly into place by means of a rude comb and driven home by sword-shaped piece of wood or "batten." The reed accomplished all this at one time.

**The Reed**

It is probable that the European looms were derived from those of India as they seem to be made on the same principle. From crude beginnings, the hand loom of our grandmothers' time developed. A loom



A JAPANESE LOOM.



**A FOUR HARNESS HAND LOOM  
Weaving Linen in the Mountains of Virginia.  
(Photograph by C. R. Dodge).**



TYPICAL COLONIAL HAND LOOM  
Two Harnesses in Use; Weaving Wool at Hull House.

has been defined as a mechanism which affects the following necessary movements:

1. The lifting of the healds to form an opening, or shed, or race for the shuttle to pass through.

**Definition  
of a Loom**

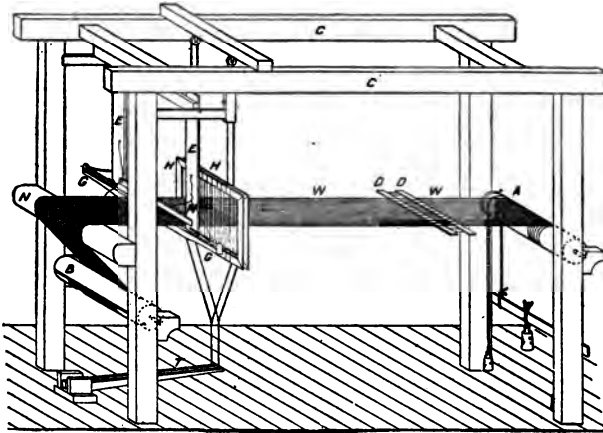

**DIAGRAM OF A HAND LOOM**

*A*—Warp Beam; *B*—Cloth Beam; *D, D*—Lees Rods; *H*—Harness,  
*T*—Treddle.

2. The throwing of the weft or filling by means of a shuttle.

3. The beating up of the weft left in the shed by the shuttle to the cloth already formed. This thread may be adjusted by means of the batten, needle, comb, or any separate device like the reed.

4 & 5. The winding up or taking up of the cloth as it is woven and the letting off of the warp as the cloth is taken up.



**SWEDISH HAND LOOM**  
Norwegian Woman Weaving Linen at Hull House.



No essential changes have been made since our grandmothers made cloth a hundred years ago. The "harnesses" move part of the warp now up, now down, and the shuttle carries the weft from side to side to be driven home by the reeds to the woven cloth. Our grandmothers did all the work with swift movements

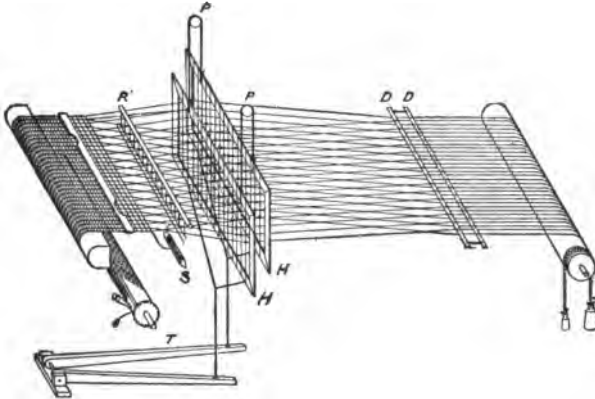

DIAGRAM OF THE WORKING PARTS OF A LOOM.

*S*—Shuttle for carrying the woof; *R*—Reed for beating up the woof;  
*H*—Frame holding heddles, with pulleys (*P*) making the harness; *T*—Treddles for moving the harness.

of hands and feet. The modern weaver has her loom harnessed to the electric dynamo and moves her fingers only to keep the threads in order. If she wishes to weave a pattern in the cloth, no longer does she pick up threads of warp now here, now there, according to the designs. It is all worked out for her on the loom. Each thread with almost human intelligence settles automatically into its appointed place, and the weaver is only a machine tender.



**FLY SHUTTLE HAND LOOM**  
The Pulling of the Reed Automatically Throws the Shuttle Back and Forth and Works the Harness, Making a Shed at the Proper Time.

No textiles of primitive people were ever woven in "pieces" or "bolts" of yards and yards in length to be cut into garments. The cloth was made of the size and shape to serve the particular purpose for which it was designed. The mat, robe, or blanket had tribal outlines and proportions and was made according to the materials and the use of common forms that prevailed among the tribes. The designs were always conventional and sometimes monotonous. The decoration never interfered with its use. "The first beauty of the savage woman was uniformity which belonged to the texture and shape of the product." The uniformity in textile, basketry, or pottery, after acquiring a family trait, was never lost sight of. Their designs were suggested by the natural objects with which they were familiar.



PICKING COTTON  
From Department of Agriculture Bulletin, "The Cotton Plant."

## FIBERS

Both the animal and vegetable kingdoms furnish the materials for clothing as well as for all the textiles used in the home. The fleece of sheep, the hair of the goat and camel, silk, furs, and skins are the chief animal products. The principal vegetable fibers are cotton, flax, ramie, jute, and hemp.

Cotton linen, wool, and silk have heretofore formed the foundation of all textiles and are the principal fibers used for clothing materials. Ramie or China grass and pineapple fibers are sometimes used as adulterants in the manufacture of silk. When woven alone, they give soft silky textiles of great strength and beauty.

Chief  
Fibers

## COTTON

Cotton is now our chief vegetable fiber, the yearly crop being over six billion pounds, of which the United States raises three-fourths. Texas is the

████████████████████	World's Crop.
████████████████████	United States.
██████████	Texas.

## PRODUCTION OF COTTON

largest producer, followed by Georgia, Alabama, and Mississippi. The remainder of the world supply comes chiefly from India, Egypt, Russia, and Brazil. The Hindoos were the first ancient people to make extensive use of the cotton fiber. Not until the invention of the cotton gin by Eli Whitney in 1794 did the cotton begin to reach its present importance. Only

four or five pounds of the fiber could be separated by hand from the seed by a week's labor. The modern saw gins turn out over five thousand pounds daily.

**Native  
Home**

Cotton is the white downy covering of the seed of several species of cotton plant. It is a native of many parts of the world, being found by Columbus growing in the West Indies and on the main land, by Cortez in Mexico, and Pizarro in Peru.

**Sea Island  
Cotton**

The value of cotton depends upon the strength, and evenness of the fiber. In ordinary cotton the individual



**COTTON FIBER ATTACHED  
TO SEED**

fiber is about an inch in length. The sea island cotton grown chiefly on the islands off the coast of Georgia, Carolina, and Florida is the most valu-

able variety, having a fine fiber, one and one-half to two inches in length. Some of the Egyptian cotton belongs to this species. Sea island cotton is used chiefly for fine laces, thread and knit goods and for the finest lawns and musins.

**Upland  
Cotton**

The short fiber or upland cotton is the most common and useful variety. It is grown in Georgia, North and South Carolina and Alabama. Texas cotton is similar to upland, but sometimes is harsh with shorter fiber. Gulf cotton occupies a position between upland and sea island cotton.

The Brazilian and Peruvian cotton yields a long staple and is sometimes used to adulterate silk and



**UPLAND COTTON PLANT WITH FULLY DEVELOPED BOLES**  
From Bulletin No. 31, Georgia Experiment Station.



**COTTON BOLL FULLY DEVELOPED**  
From Year Book of the Department  
of Agriculture, 1903.





**BOLE OPENED, COTTON READY FOR PICKING**  
Year Book of 1903.

other fibers. Some varieties of this cotton are harsh and woolly and are prized for use in mixing with wool.

**Nankin  
Cotton**

The Nankin cotton grown in China and India and in the southwestern part of Louisiana is characterized by its yellow color. It is used in weaving cloth of various kinds in the "fireside industries" which have become popular in the United States and England.

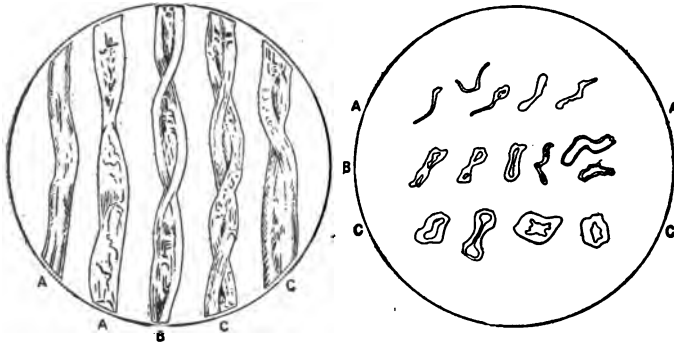

COTTON FIBERS

*A A*—Unripe Fibers; *B B*—Half-ripe Fibers; *C C*—Ripe Fibers.

**Spinning  
Qualities**

Very fine yarn can be spun from cotton because of the spiral character of the fibers. This twist of the fibers is peculiar to cotton, being present in no other animal or vegetable fiber. On account of this twist, cotton cloths are much more elastic in character than those woven from linen, the fibers of which are stiff and straight.

After the removal of the seed, no other fiber is so free from impurities—5 per cent is the loss sustained

by cleaning and bleaching. In its natural condition, cotton will not dye readily because of a waxy substance on the surface of the fibers. This must be removed by washing.

Cotton should be picked only when it is fully ripe when the pods are fully burst and the fibers expanded. The unripe fiber is glassy, does not attain its full

**Picking  
and  
Ginning**

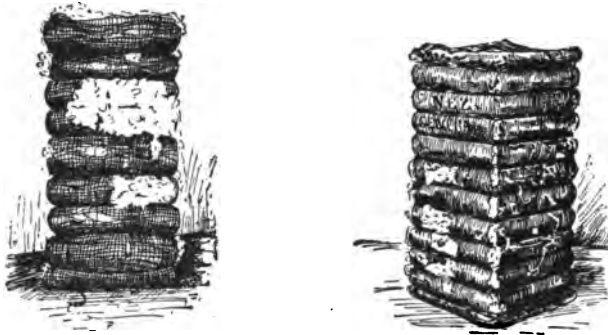

COTTON BALES

strength and resists the dye. After picking, the cotton is sent to the ginning factory to have the seed removed. It is then pressed into bales by hydraulic presses, five hundred pounds being the standard bale in the United States.

Purified bleached cotton is nearly pure cellulose. It resists the action of alkalis well, but is harmed by hot, strong acids, or if acid is allowed to dry on the fabric. It is not harmed by high temperature, and so may be ironed with a hot iron.

**Physical  
Character-  
istics**

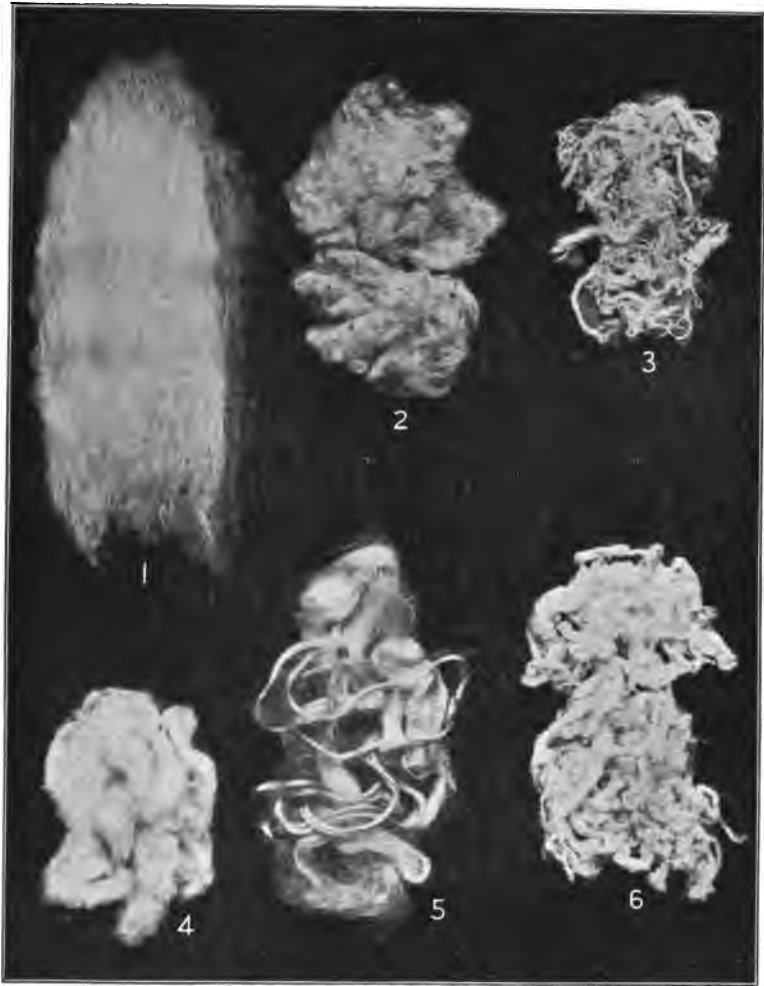

**WOOL FIBER AND SUBSTITUTES**

- 1, South American Wool; 2, Noil from the Same; 3, Tangled Waste; 4, Waste Combed Out; 5, Lap Waste; 6, Shoddy.

## WOOL

Wool is the most important animal fiber. Strictly speaking the name applies only to the hairy covering of sheep, but the hair of certain goats and of camels is generally classified under the same terms. The wool fiber is distinguished by its scale-like surface which gives it its felting and spinning properties. Hair

**Character  
of Fiber**

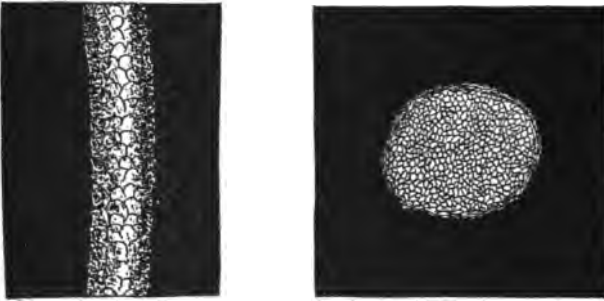

**MICROSCOPIC APPEARANCE OF WOOL FIBERS**

as distinguished from wool has little or no scaly structure being in general a smooth filament with no felting properties and spinning only with great difficulty. Fur is the undergrowth found on most fur-bearing animals and has in a modified way the scaly structure and felting properties of wool.

The great value of wool as a fiber lies in the fact that it is strong, elastic, soft, very susceptible to dye stuffs and being woven, furnishes a great number of

**Value for  
Clothing**

air spaces, rendering clothing made from it very warm and light.

**Quality  
of Wool**

Climate, breed, and food influence the quality of the wool. Where the pasturage is barren and rocky, the wool is apt to be coarse.



**MERINO RAMS**

The Variety of Sheep Giving the Finest Wool.

**Varieties  
of Sheep**

There are supposed to be about thirty distinct varieties of sheep, nearly half of which are natives of Asia, one-third of Africa, and only four coming from Europe, and two from America. Wool is divided into two general classes—long and short staple, according

to the average length of fiber. The long fiber wool is commonly carded, combed and spun into *worsted* yarn. The short fiber is usually carded and spun into woolen yarn. The short fiber obtained in combing long staple wool is called "noil." It is used for woolens.

Alpaca, Vicuna and Llama wools are obtained from animals which are native to the mountains of Peru

Goat  
Wools

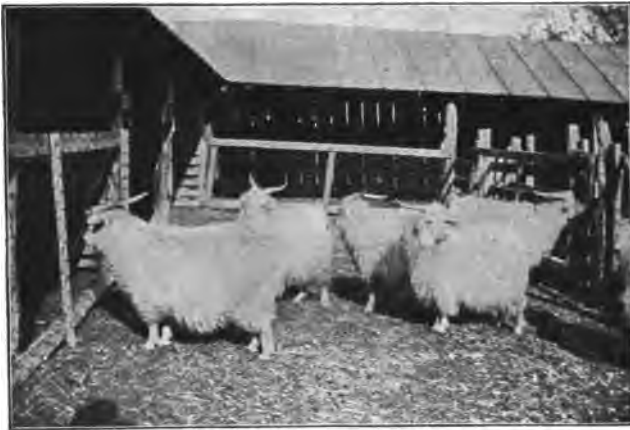

ANGORA GOATS

and Chile. The Angora goat, originally from Asia Minor, furnishes the mohair of commerce. This fiber does not resemble the hairs of common goats in any respect. It is a very beautiful fiber of silky luster, which constitutes its chief value.

**Fur** The fur of beavers and rabbits can be and is used in manufacture, either spun into yarn or made into felt. The fibers of both animals enter largely into the manufacture of felt hats.

**Sorting  
Wool**

The fleece of sheep after being sheared is divided into different parts or *sorted*, according to to the qual-

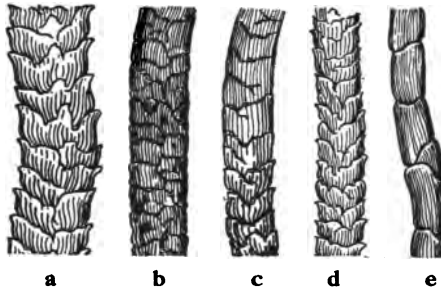

WOOL FIBERS

*a*—Medium Wool; *b*—Camel's Hair; *c*—Diseased Fiber; *d*—Merino Wool;  
*e*—Mohair.

ity of the wool, the best wool coming from the sides of the animal.

**Scouring  
Wool**

As it comes from the sheep, the wool contains many substances besides the wool fiber which must be removed before dyeing or spinning. This cleansing is called *scouring*. Before scouring, the wool is usually dusted by machines to remove all loose dirt. The scouring must be done by the mildest means possible in order to preserve the natural fluffiness and brilliancy of the fiber. The chief impurity is the wool



grease or "yolk" which is secreted by the skin glands to lubricate the fiber and prevent it from matting.

In the scouring of wool, soap is the principal agent. Soft soap made from caustic potash is generally used

Scouring  
Agents

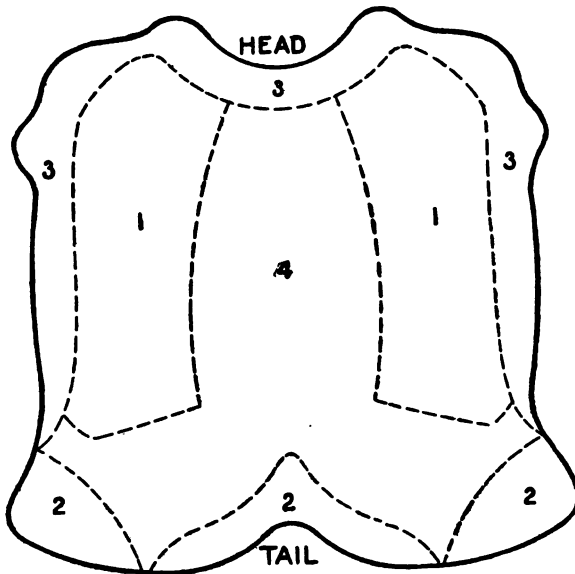

ONE METHOD OF WOOL SORTING

1—The Best Grade; 2—Lowest Grade; 3—Fair; 4—Medium Grade.

as it is less harmful than ordinary hard soda soap. Potassium carbonate—"pearl ash"—is often used in connection with the soap. If the water for scouring is hard, it is softened with pearl ash. The temperature

of wash water is never allowed to go above 120° F. The scoured wool weighs from a little over a half to one-third or less of the weight of the fleece.

**Hygroscopic  
Moisture**

Wool has the remarkable property of absorbing up to 30 per cent or more of its weight of water and yet not feel perceptibly damp to the touch. This is called

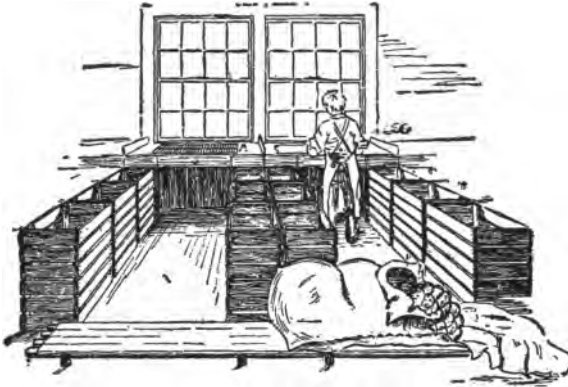

WOOL SORTING

“hygroscopic moisture.” To this property wool owes its superiority as a textile for underclothing.

The thoroughly cleansed fiber is made up chiefly of the chemical substance keratin, being similar in composition to horn and feathers. In burning it gives off a characteristic disagreeable odor. It is a substance very weakly acid in its nature, for which reason it combines readily with many dyes. Wool resists the action of acids very well, but is much harmed by the alkalis, being dissolved completely by a warm solution of caustic soda. High temperature harms wool.

**FLAX**

Next to wool and cotton, flax is used most largely in our textile manufactures. The linen fiber consists of the bast cells of certain species of flax grown in Europe, Africa, and the United States. All bast fibers are obtained near the outer surface of the plant stems. The pith and woody tissues are of no value. The flax plant is an annual and to obtain the best fibers it must be gathered before it is fully ripe. To obtain seed from which the best quality of linseed oil can be made it is usually necessary to sacrifice the quality of the fibers to some extent.

**Treatment  
of Flax**

Unlike cotton, flax is contaminated by impurities from which it must be freed before it can be woven into cloth. The first process to which the freshly pulled flax is submitted is that of "rippling" or the removal of the seed capsules. Retting, next in order, is the most important operation. This is done to remove the substances which bind the bast fibers to each other and to remove the fiber from the central



**A FIELD OF FLAX IN MINNESOTA  
The Flax Must Be Pulled Up by the Roots to Give Fibers with Tapered Ends.  
(Photograph of C. R. Dodge).**

woody portion of the stem. This consists of steeping the stalks in water.

- (1) Cold water retting, either running or stagnant water.
- (2) Dew retting.
- (3) Warm water retting.

**Retting**

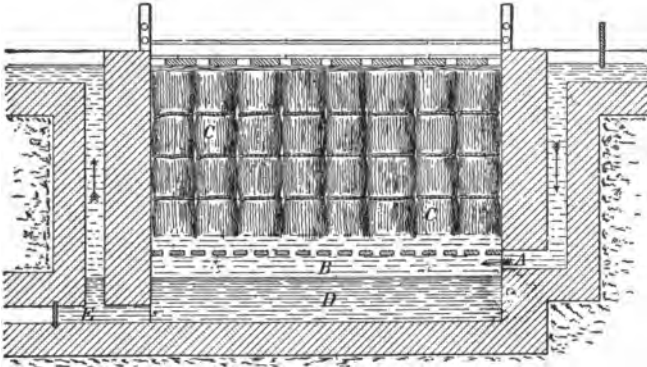

**RETTING TANK**

*A*—Inlet; *B*—Undisturbed Water; *C*—Bundles of Flax.

Cold water retting in running water is practiced in Belgium. Retting in stagnant water is the method usually employed in Ireland and Russia. The retting in stagnant water is more rapidly done, but there is danger of over-retting on account of the organic matter retained in the water which favors fermentation. In this case the fiber is weakened.

In dew retting, the flax is spread on the field and exposed to the action of the weather for several weeks

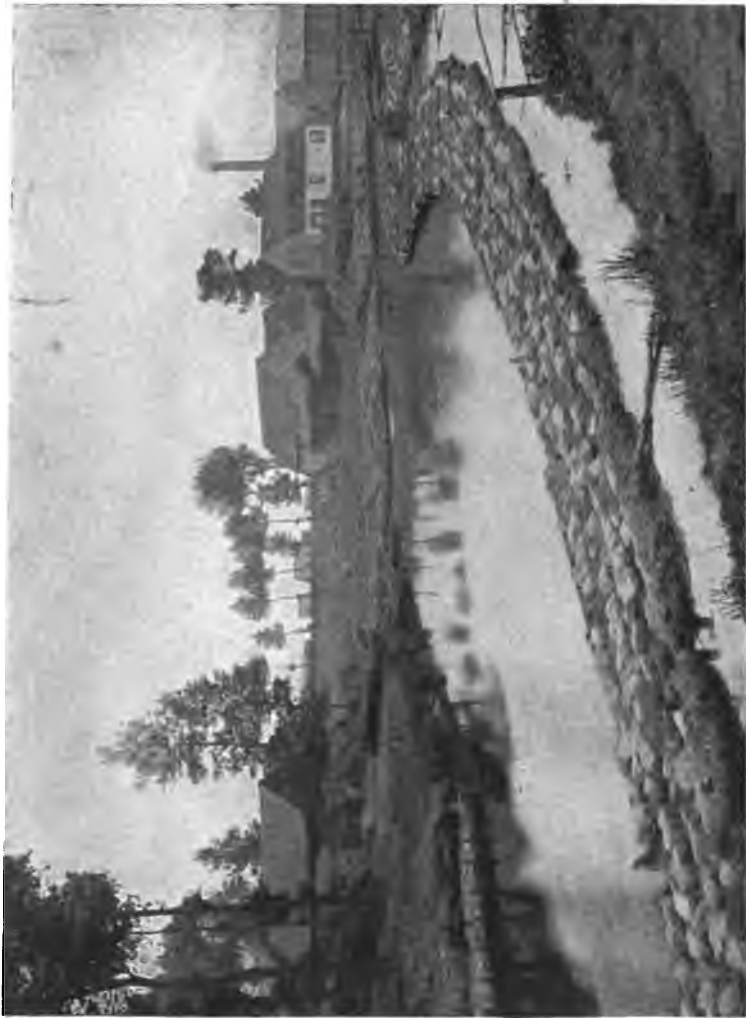

RETING FLAX IN THE RIVER LYS, BELGIUM  
From the Government Bulletin, "Flax for Seed and Fiber."

without any previous steeping. This method of retting is practiced in Germany and Russia. Warm water retting and chemical retting have met with limited success.

When the retting is complete, the flax is set up in sheaves to dry. The next operations consist of "breaking," "scutching," and "hackling" and are now done by machinery.

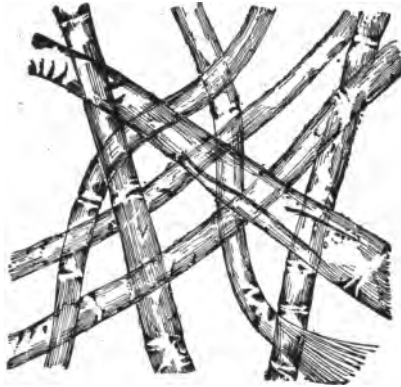

FIBERS OF FLAX

Breaking removes the woody center from the retted and dried flax by being passed through a series of fluted rollers. The particles of woody matter adhering to the fibers are detached by scutching.

Hackling or combing still further separates the fibers into their finest filaments—"line" and "tow." The "flax line" is the long and valuable fiber; the tow, the short coarse tangled fiber which is spun and used for weaving coarse linen.

**Hackling**

When freed from all impurities the chief physical characteristics of flax are its snowy whiteness, silky luster and great tenacity. The individual fibers may

**Character-  
istics of  
Linen**



**FLAX**  
A, Unthrashed Straw; B, Retted; C, Cleaned or Scutched; D,  
Hackled or Dressed.  
(Photograph of C. R. Dodge).





**HACKLING FLAX BY HAND**

The "Tow" Is Seen at the Left and a Bunch of "Flax line" on the Bench.

(Photograph of C. R. Dodge, Special Agent U. S. Department of Agriculture.)

be from two to twelve inches in length; they are much greater in diameter than cotton. It is less pliant and elastic than cotton and bleaches and dyes less readily. Linen cloth is a better conductor of heat than cotton and clothing made from it is cooler. When pure, it is, like cotton, nearly pure cellulose.

Besides the linen, there is a great number of bast fibers fit for textile purposes, some superior, some inferior. India alone has over three hundred plants that are fiber yielding. One-third of these furnish useful fibers for cordage and fabrics. The next in importance to linen is ramie or rhea, and China grass. China grass comes from a different plant but is about the same as ramie. The staple is longer and finer than linen. The great strength of yarn made from it is due to length of the staple.

**Ramie**

The variety and great value of the ramie fibers has long been recognized, but difficulties attending the separation and degumming of the fibers have prevented its employment in the manufactures to any great extent. The native Chinese split and scrape the plant stems, steeping them in water. The common retting process used for flax is not effective on account of the large amount of gummy matter, and although easy to bleach it is difficult to dye in full bright shades without injuring the luster of the fibers.

**Jute  
and  
Hemp**

Jute and hemp belong to the lower order of bast fibers. The fiber is large and is unfit for any but the



**JUTE GROWING IN LOUISIANA**  
From Culture of Hemp and Jute, Report of U. S. Department of  
Agriculture.



**DRYING HEMP IN KENTUCKY**  
From "Culture of Hemp and Jute."

coarsest kind of fabrics. Jute is mainly cultivated in Bengal. The fiber is separated from the plant by retting, beating, etc.

Olona, the textile fiber of Hawaii, is found to have promising qualities. This plant resembles ramie and belongs to the nettle family also, but it is without the troublesome resin of the ramie. The fiber is fine, light, strong, and durable.

Olona

The Philippines are rich in fiber producing plants. The manila hemp is the most prominent, of which coarse cloth is woven, besides the valuable cordage. The sisal hemp, pineapple, yucca, and a number of fiber plants growing in the southern part of the United States are worthy of note. These fiber industries are conducted in a rude way, the fiber being cleaned by hand, except the pineapple.

## SILK

The silk fiber is the most perfect as well as the most beautiful of all fibers. It is nearly faultless, fine and continuous, often measuring from 1000 to 4000 feet long, without a scale, joint, or a blemish, though not of the same diameter or fineness throughout its entire length, as it becomes finer as the interior of the cocoon is approached. Silk differs from all other vegetable or animal fibers by being devoid of all cellular structure.

Southern Europe leads in the silk worm culture—**Where Produced** Italy, southern France, and Turkey, with China and India. Several species of moths, natives of India, China, and Japan, produce the wild silk. The most

important of the "wild silks" are the Tussah. Silk plush and the coarser varieties of buff colored fabrics are made of this silk. While manufacturers do not favor the wild silk, the coarse uneven weave and softness make it a favorite with artists and it is being used for interior decoration as well as for clothing.

**Silk  
Worm**

The silk of commerce begins with an egg no bigger than a mustard seed, out of which comes a diminutive caterpillar, which is kept in a frame and fed upon mulberry leaves. When the caterpillars are full grown, they climb upon twigs placed for them and begin to spin or make the cocoon. The silk comes from two little orifices in the head in the form of a glutinous gum which hardens into a fine elastic fiber. With a motion of the head somewhat like the figure eight, the silk worm throws this thread around the body from head to tail until at last it is entirely enveloped. The body grows smaller and the thread grows finer until at last it has spun out most of the substance of the body and the task is done.

If left to itself, when the time came, the moth would eat its way out of the cocoon and ruin the fiber. A few of the best cocoons are saved for a new supply of caterpillars; the remainder are baked at a low heat which destroys the worm but preserves the silk. This now becomes the cocoon of commerce.

**Reeling  
Silk**

Next the cocoons go to the reelers who wind the filaments into the silk yarn that makes the raw ma-

terial of our mills. The cocoons are thrown into warm water mixed with soap in order to dissolve the gum. The outer or coarser covering is brushed off down to



**SILK:—CATERPILLAR, COCOON, CHRYSALIS, MOTH**

the real silk and the end of the thread found. Four or five cocoons are wound together, the sticky fibers clinging to each other as they pass through the various guides and are wound as a single thread on the reels.

The silk is dried and tied into hanks or skeins. As the thread unwinds from the cocoon, it becomes smaller, so other threads must be added.

**Organise  
and  
Tram**

At the mill the raw silk goes to the "throwster" who twists the silk threads ready for the loom. These threads are of two kinds—"organize" or warp and "tram" or filling. The warp runs the long way of woven fabric or parallel with the selvage and it must be strong, elastic, and not easily parted by rubbing. To prepare the warp, two threads of raw silk are slightly twisted. Twist is always put into yarn of any kind to increase its strength. These threads are united and twisted together and this makes a strong thread capable of withstanding any reasonable strain in the loom and it will not roughen. For the woof or tram which is carried across the woven cloth on the shuttle, the thread should be as loose and fluffy as possible. Several threads are put together, subjected to only a very slight twist—just enough to hold the threads together so they will lie evenly in the finished fabric.

**Boiling  
Off**

After the yarn leaves the spinners it is again run off on reels to be taken to the dye house. First the yarn is boiled off in soapy water to remove the remaining gum. Now the silk takes on its luster. Before it was dull like cotton. The silk is now finer and harder and is known as "souple."

**Loading  
Silk**

The silk fiber has a remarkable property of absorbing certain metallic salts, still retaining much of its



luster. This process is known as "loading" or "weighting," and gives increased body and weight to the silk. Silk without weighting is known as "pure dye," of which there is little made, as such goods take too much silk.

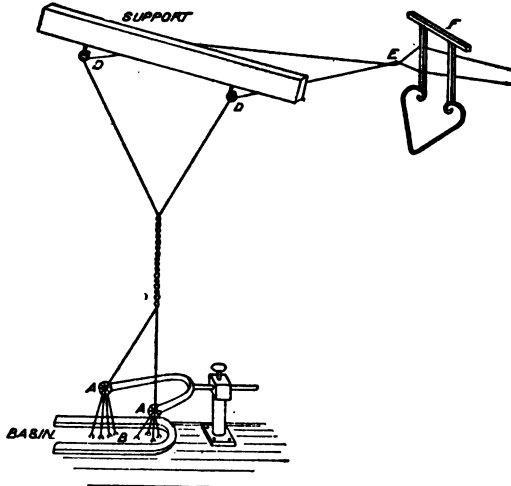

REELING SILK

For the weighting of white or light colored silk goods, tin crystals (stannous chloride) are used and for dark shades and black, iron salts and tannin. By this means the original weight of the fiber may be increased three or four hundred per cent. This result is not attained, however, except through the weakening of the fiber.

**Action of  
Common  
Salt**

Common salt has a very curious action on weighted silk. It slowly weakens the fiber. A silk dress may be ruined by being splashed with salt water at the seashore. Most often holes appear after a dress comes back from the cleaners; these he may not be to blame for, as salt is abundant in nearly all the bodily secretions,—tears, perspiration, urine.

**Artificial  
Silk**

Artificial silk is made by dissolving cellulose obtained from cotton. It is lacking in strength and water spoils all kinds manufactured at present.

**Character-  
istics  
of Silk**

Silk, like wool, has the property of absorbing considerable moisture without becoming perceptibly damp. Like wool and all the animal fibers, it is harmed by alkalis. The important physical properties of silk are its beautiful luster, strength, elasticity and the readiness with which it takes dyes. Silk combines well with other fibers, animal and vegetable.

**Value of  
Raw Fibers**

A comparison of the relative value of textile fibers may be seen from the following approximate prices:

Cotton—\$.07 to \$.14 per pound; loss in cleaning and bleaching 5 per cent.

Flax—\$.12 to \$.30 per pound; loss in cleaning and bleaching about 20 per cent.

Wool—\$.15 to \$.30 per pound; loss in scouring 20 to 60 per cent.

Raw Silk—\$7.00 to \$10.00 per pound; loss in "boiling off" about 30 per cent which is made up and much more by "loading."

## MODERN METHODS

All the complex processes and machinery of the textile industry are but developments of the old-time methods of the home. Brief outlines only will be given here for the processes are most intricate in detail.

### SPINNING

The spinning of cotton yarn (thread) is typical of all the fibers. The stages may be divided into—

1. Opening and picking.
2. Carding.
3. Combing.
4. Drawing.
5. Spinning.

The picking and carding have for their object the removal of all foreign substances with as little damage to the fiber as possible. The foreign substances in cotton are sand, dirt, pieces of leaves, seed, husk, etc., which have become mixed with the fiber during the process of growing, ginning and transportation.

**Picking  
and  
Carding**

The cotton bales are opened and thrown into the automatic feeder which carries up a layer of cotton on a spiked apron from which it is removed by a rapidly revolving "doffer" underneath which is a screen which catches some of the dirt. It is next fed between rolls in front of a rapidly revolving blunt-edged knife which throws out more of the dirt through a screen. There is a suction of air through the screen which helps remove the foreign substances. The cotton passes

**Cleaning**

through several of such machines, being formed into a soft web or "lap" which is wound into a roll.

**Carding**

The carding machine further cleans the fibers and lays them in a general parallel position. From this machine the web is formed into "sliver," a loose rope

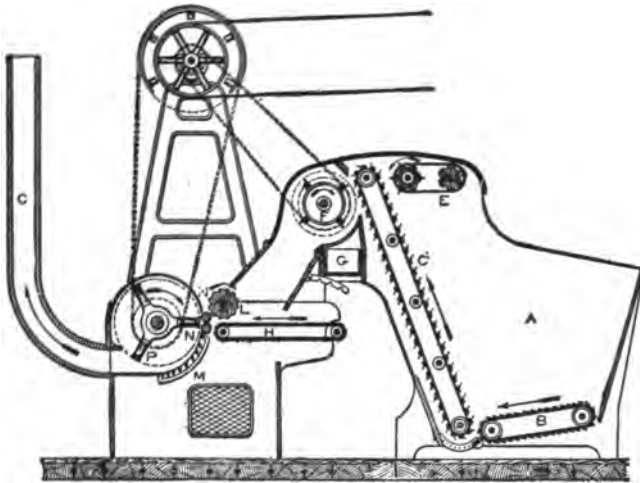

**COTTON OPENER AND PICKER**

The cotton from the bale is thrown into *A*, carried by the spiked aprons *B* and *C*, evened by *E*, removed from the apron by *F* (some of the dirt falls through the screen into box *C*) is beaten by the revolving "knife," *N*, more dirt being removed through screen *N*, then goes through the flue *C* to the next machine.

of cotton fiber about two inches in diameter. This is received in circular cans.

**Combing**

The combing is omitted for short fiber cotton, but is used in worsted spinning and with long staple cotton to remove the short fibers. Cotton to be used for

making yarn suitable for hosiery, underwear, sewing thread, lace, and for very fine cotton fabrics is carded.

In drawing, from six to sixteen "slivers" are run together and the fibers drawn out in several stages until the soft rope is about an eighth of an inch in diameter, called "roving." This tends to get rid of any unevenness and makes the fibers all parallel. From this machine the roving is wound on a bobbin ready for the spinning frame.

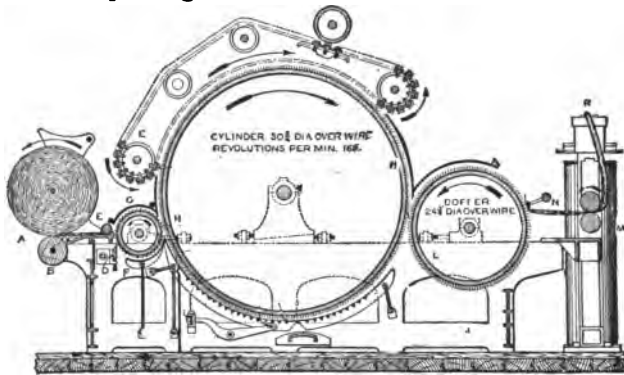

COTTON CARD

The roll of webbing *A* is beaten and transferred to the cylinder *HH*, carded by the spiked belt *E*, removed by the "doffer" and formed into a "sliver" which runs into the can *M*.

The spinning frame may have a hundred spindles or more, each one of which is drawing out its supply of "roving" to the required size of yarn and giving it the twist necessary to bind the fibers together. The yarn to be used for the warp is given a harder twist so that it may be strong enough to stand the strain in weaving. The yarn for filling is usually left soft.

Spinning

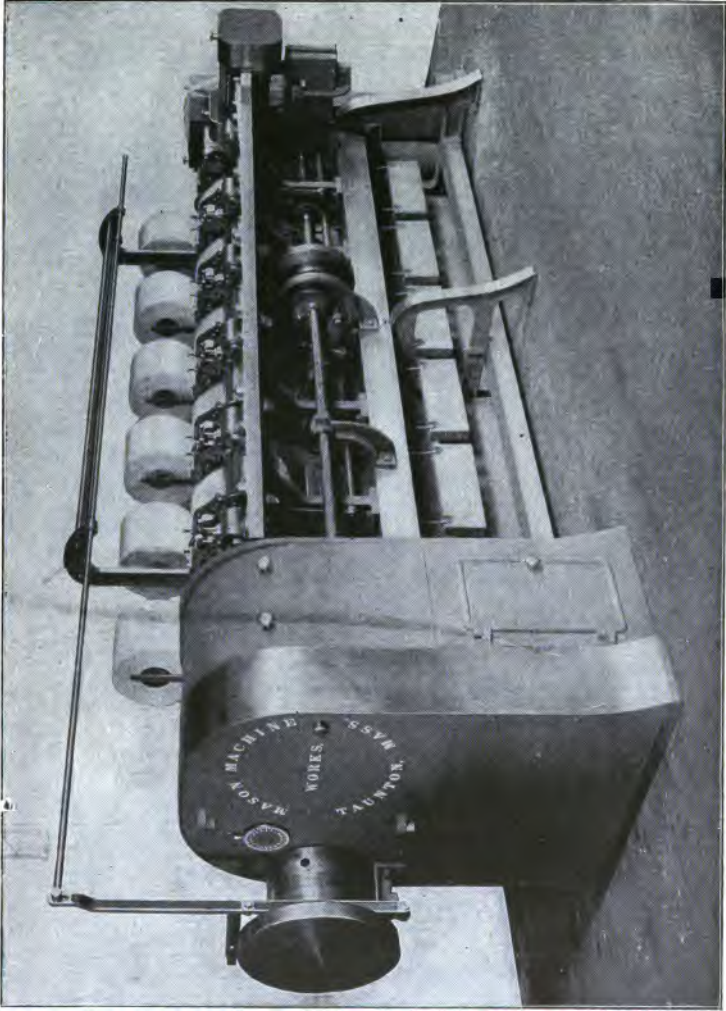

COTTON COMB, USED FOR LONG STAPLE



RECEIVING THE "SLIVER" AT THE BACK OF THE DRAWING FRAME.



**DRAWING FRAME.**  
Drawing the Roving Finer.



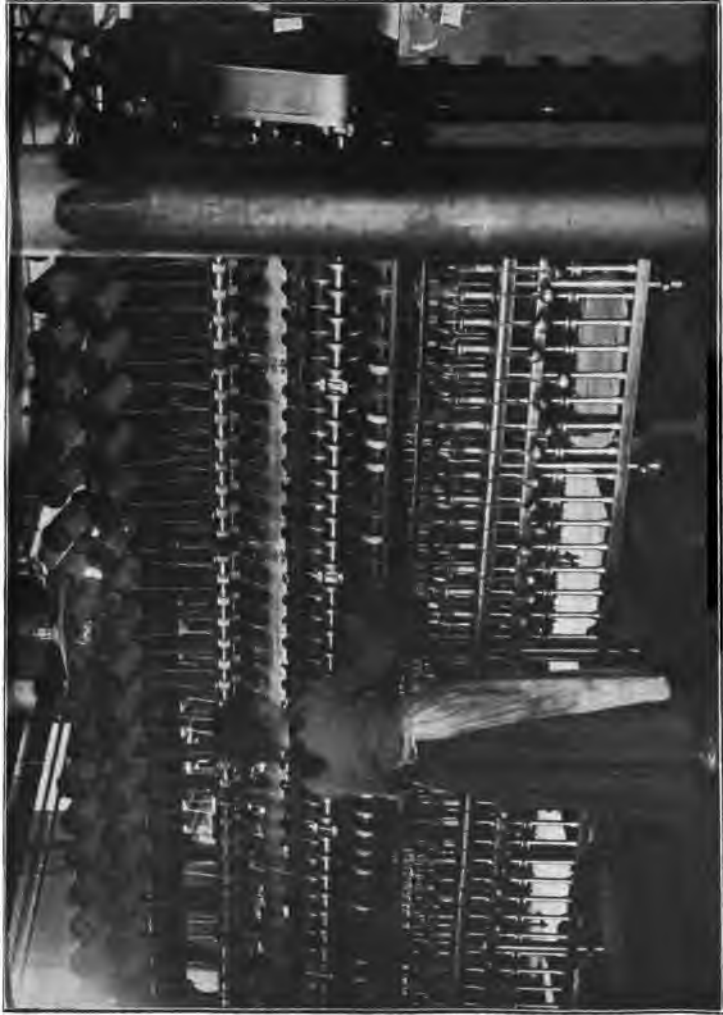

**A FLY SPINNING FRAME**  
The Spools of Roving Above Are Being Drawn Out Given the Twist by the Filers, and Wound on Bobbins Below.

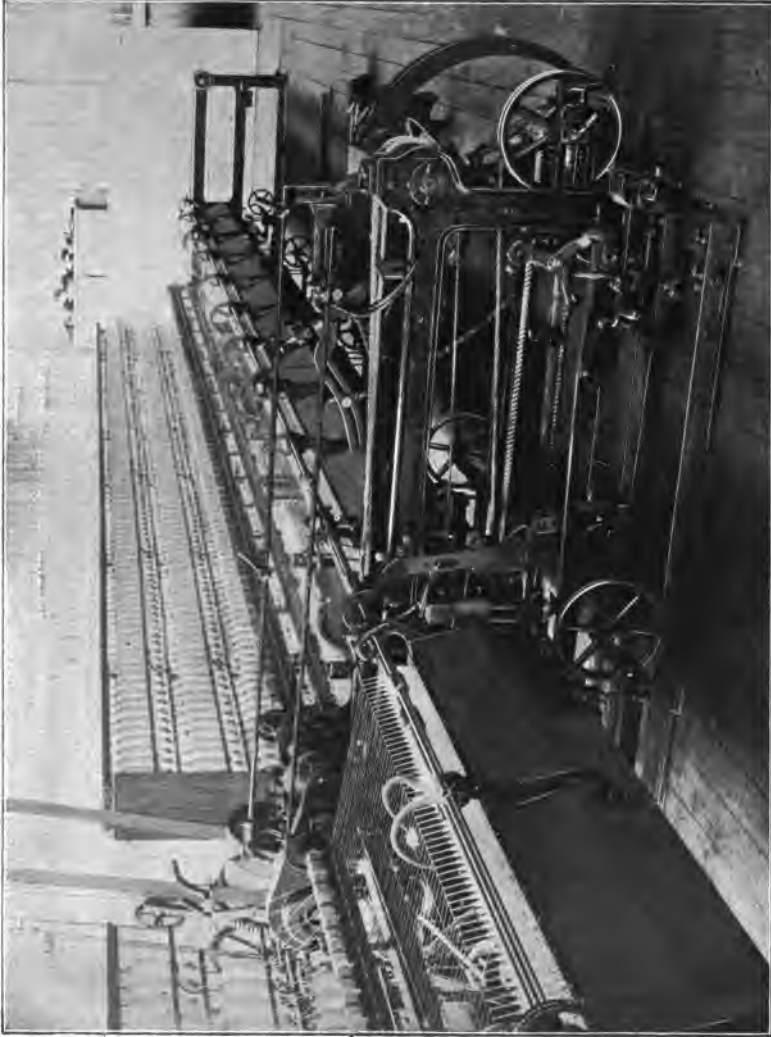

**MULE DRAWING AND SPINNING FRAME]**  
Always used for wool. Part of the machine moves away from the frame, thus drawing out the thread, which is then twisted.



**MODERN RING SPINNING FRAME FOR COTTON. SIXTY-EIGHT SPINDLES**  
Gives the Largest Production.

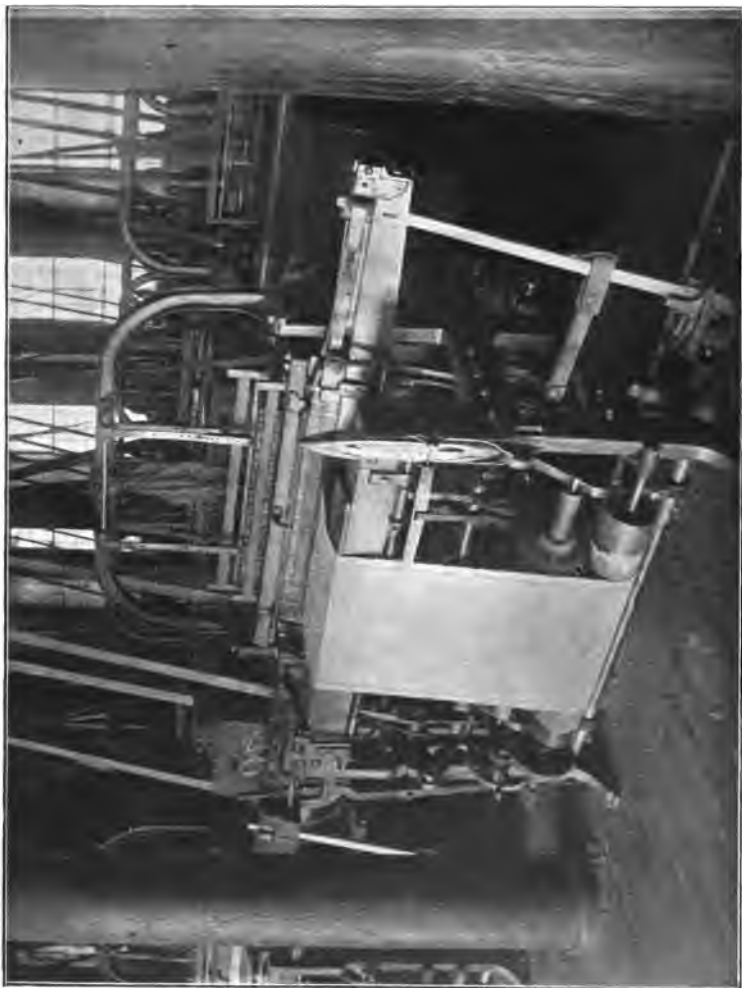

A PLAIN POWER LOOM WEAVING LINEN

The yarn for warp is now usually given a coating or "sizing" of starch and gums so that the thread may not become unwound and break during weaving.

The process of spinning is much the same for flax and for wool, although somewhat differently constructed machines must be used. Flax is usually spun wet.

#### WEAVING

The modern power driven loom is a wonderful piece of machinery. The principle of its operation is essentially the same as the hand loom, but it is almost perfectly automatic in its action, a man or woman being able to tend from ten to fifteen looms weaving plain cotton goods.

**Modern  
Loom**

The yarn coming from the spinning frame is sometimes dyed before weaving. The warp is formed by winding as many threads as the width of the fabric is to contain on a slowly revolving drum, called a "beam," in the same relative position in which they are to appear in the finished cloth. From its position on the beam at the back of the loom, each thread is brought through its particular loop or eye with the heddle, then passes through its own slot in the reed, and down to the roller or "cloth beam" that is to take up the woven cloth. This is called "drawing in the warp." If there is a piece of cloth coming from the loom, the work is very simple, for the ends of the new warp are tied to the ends remaining from the warp that has been woven out.

**Warping**

The shuttle with its bobbin, containing the yarn of the filling, is much the same as is used in the hand looms, except for form and size, which varies according to the requirements and size of the warp being used. At first only one shuttle was used, but in 1760 Robert Kay invented a mechanism by which several shuttles containing different grades or colors of yarn might be used. Each throw of the shuttle across the width of the goods is called a "pick."

**The  
Harness**

In making a cloth with plain weave, that is, with every thread interlacing with every other, as in darning, only two harnesses are required, but the modern loom may have up to about twenty-four harnesses so that an infinite variety of weaves may be obtained. Various cams and levers move the harness frame and so raise or lower the threads required for the design.

**Jacquard  
Loom**

The Jacquard loom is arranged on a different principle. In this loom, all kinds of fancy weaves may be obtained as in table linen, tapestries and carpets. Each warp thread is supplied with a separate hook and by means of perforated card the desired threads are raised or depressed at each throw of the shuttle. The cards are worked out by the designer. A set of a thousand or more cards may be required to produce the desired design. Jacquard looms are sometimes to be seen at fairs and exhibitions weaving handkerchiefs with some picture design.



**JACQUARD HAND LOOM**  
Weaving Ingrain Carpet at Hull House.

## WEAVES

The great variety of weaves found in the textiles of to-day are modifications of a few fundamental weaves invented in the earliest times.

The chief fundamental weaves are:

- (1) Plain weave.
- (2) Twills.
- (3) Sateen.

To which may be added the derivatives—

- (4) Rib weave.
- (5) Basket weave.

These do not include the many fancy weaves, too

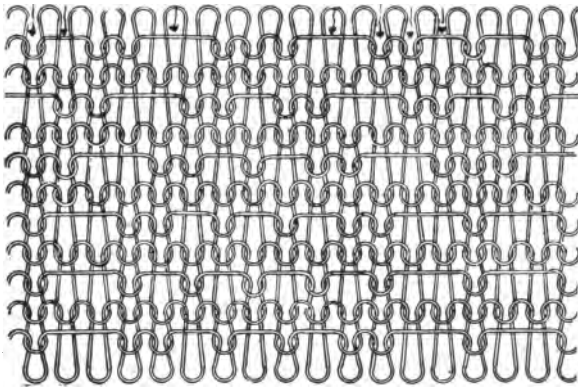
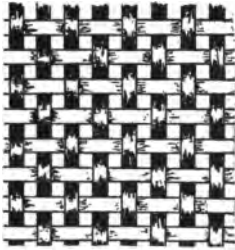

DIAGRAM OF FANCY KNIT GOODS

numerous to classify, and the open work weaves, made in the Leno loom, in which some of the threads are crossed. Knit goods are made by the interlooping of a single thread, by hand or on circular knitting ma-



chines and lace by an analogous process, using several systems of threads. Felt is made up of matted fibers of fur and wool and has no thread structure.



Plain

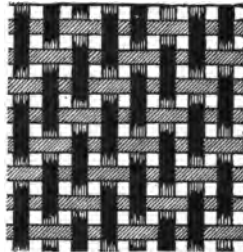

Twill

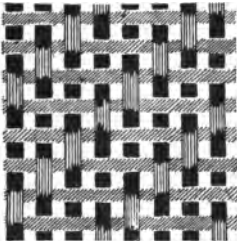

Cassimere Twill

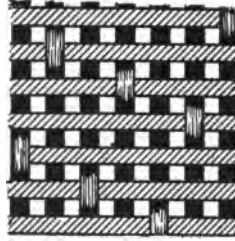

Sateen

## WEAVE DIAGRAMS

The plain weave is the most common, nearly all light weight goods being thus woven. In plain weaving, each thread of both warp and filling passes alternately over and under the threads at right angles. This makes a comparatively open cloth, requiring the

**Plain  
Weave**

smallest amount of yarn for the surface covered. This weave is used in nearly all cotton goods, as in muslins, sheetings, calicoes, gingham, and thin woolen goods. Even in the plain weave variety is obtained by having



a



b



c



d

## SECTIONS OF WEAVES

a—Plain weave; b—Prunella twill; c—Cassimere twill; d—Swans-down twill.

some of the threads larger than others, either in warp or filling or both, thus producing stripes and checked effects.

**Twills**

After the plain weave the twill is the most common, being much used for dress goods, suitings, etc., as well as some of the thicker cottons. In this weave the intersections of the threads produce characteristic lines diagonally across the fabric, most often at an angle of  $45^{\circ}$ . The twill may be hardly visible or very

pronounced. The simplest twills are the so-called "doeskin" and "prunella." In the doeskin the filling threads pass over one and under two of the warp threads and in the prunella twill over two and under one. The most common twill is the cassimere twill in which both the warp and filling run over two and under two of the threads at right angles.

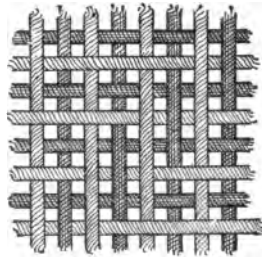
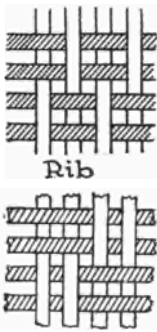

**Double Cloth**

### **Basket**

#### **DIAGRAM OF RIB AND BASKET WEAVE AND DOUBLE CLOTH**

A twill made by running both warp and filling under one and over three threads is called a swansdown twill and the reverse is known as the crow weave. In these the diagonal twilled effect is much more marked. Various twills are often combined with each other and with plain weave, making a great variety of texture. Numerous uneven twills are made, two over and three under, etc., etc.

**Uneven  
Twill**

**Sateen Weave**

In the sateen weave, nearly all of either the warp or the filling threads are on the surface, the object being to produce a smooth surface fabric like sateen. With

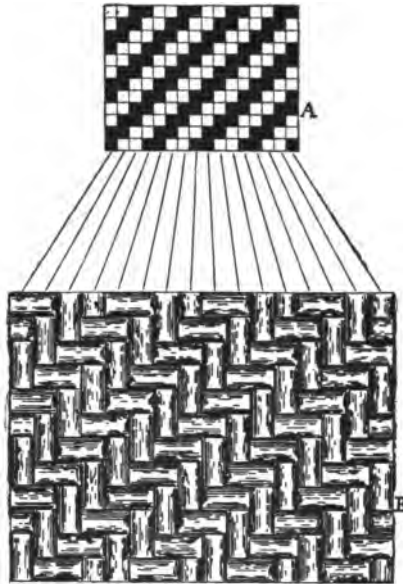

TEXTILE DESIGN

*A*—On cross-section paper; *B*—Graphic diagram.

this weave it is possible to use a cotton warp and silk filling, having most of the silk appear on the surface of the fabric.

**Rib and Basket Weaves**

The rib and basket weaves are derivatives of the plain weave, two or more threads replacing the single

strand. In the rib weave, either the warp or the filling threads run double or more, thus making a corded effect. In the basket weave, both warp and filling are run double or treble, giving a coarse texture. This weave is sometimes called the panama weave.

In the thicker fabrics like men's suitings and overcoatings, there may be a double series of warp threads, only one series appearing on the face of the goods, and in the still thicker fabrics, there may be a double set of both warp and filling threads, making double cloth, the two sides of which may be entirely different in color and design.

**Double  
Cloth**

In weaving plush, velvet and velveteen, loops are made in the filling or warp threads which are afterwards cut, producing the pile.

**Velvet**

## BLEACHING, DYEING, PRINTING, FINISHING

When the cloth comes from the loom it is by no means ready for the market. Nearly all kinds are washed and pressed and in some classes of goods the finishing process is very elaborate.

### BLEACHING AND DYEING

The fiber may be dyed in a loose or unspun state, as is customary with wool; after it has been spun and is in the form of yarn, as in the case of silk and linen; and when it has been woven to form cloth, as is most commonly the case with cotton.

#### Madder Bleach

The bleaching of cotton involves a number of steps, the most thorough process being called the "madder bleach," in which the cloth is (1) wet out, (2) boiled with lime water, (3) rinsed, (4) treated with acid, (5) rinsed, (6) boiled with soap and alkali, (7) rinsed, (8) treated with bleaching powder solution, (9) rinsed, (10) treated with acid, (11) finally rinsed again. All this is done by machines and hundreds of yards go through the process at a time. The product is a pure white cloth suitable for dyeing light shades and for white goods. When cloth is to be dyed a dark shade the treatment is less elaborate.

#### Singeing and Shearing

If the cloth is to be printed for calicoes, before bleaching it is singed by passing through gas flames or over a red hot plate and then sheared in a shearing machine constructed somewhat on the principle of the

lawn mower, the cloth being run close to the rapidly revolving knives.

Although cotton is usually dyed in the piece, it may be dyed in the form of yarn, as for gingham, and sometimes before being woven, in the loose state.

Cotton is more difficult to dye than wool or silk. Although there are now what are called "direct" cotton colors, the usual process is to first treat the cotton goods with a "mordant"—various salts of aluminum, chromium, iron, tin and copper, fixing these on the fiber by means of tannin or alkali. The mordanted cloth is then entered into the dye bath and boiled for an hour or longer, until the desired shade is obtained or the dye bath exhausted. The salts of aluminum are used as mordants for the lighter shades, the salts of chromium for the medium shades, and iron for the dark shades. In general, chromium mordants give the fastest dyes.

**Mordant  
Colors**

The discovery of the so-called aniline dyes has greatly increased the variety of colors available. Although some of the first aniline dyes to be made were not fast to washing or to light and they thus received a bad reputation, they are now to be obtained which compare favorably in fastness with the natural dye stuffs such as cochineal, madder, etc., provided sufficient time and care are given to dyeing. The chief trouble is that in the endeavor to furnish cheap goods, processes are hurried and results are unsatisfactory.

**Aniline  
Dyes**

**Home  
Dyeing**

Home dyeing is practically confined to the use of direct aniline colors. These are put up in small quantities and sold in many places. Directions for their use are given on the packages. The chief precautions are to have the goods perfectly clean and thoroughly wet before entering into the dye bath (this is by no means as easy as one might think), and to keep the goods in motion while dyeing so as to prevent unevenness of shade. Wool and silk dyes cannot be used for cotton and linen, nor the reverse. Of course cloth already colored cannot be dyed a lighter shade of the same color and the original shade must be very light to enable one to change the color, say from red to blue, etc. The original color always modifies that of the dye somewhat and it is best to experiment first with a small portion of the dye and cloth. Rather dark shades are apt to be most successful.

**Natural  
Dyestuffs**

Indigo for blue, madder for Turkey red, logwood for fustic for black, cutch or gambia for browns on cotton are about all the natural dyestuffs which are used to any extent commercially at the present time. The artificial product alizerin, the active principle of madder, has about superseded the natural dyestuff, and artificial indigo is gaining on the natural product.

Linen is bleached and dyed in much the same manner as cotton. This weakens linen more than cotton and the finest table linens are whitened by grass bleaching or a combination of grass and chemical bleach.

**Dyeing  
Woolen  
and Silk**

Woolen and silk may be dyed directly with a great variety of dyes without the addition of a mordant,



although they are often mordanted. Both must be well washed or scoured before dyeing. When white or delicate shades on woolen or silk are desired they are bleached. The bleaching is usually done with sulphurous acid gas, the cloth or yarn being exposed in a damp condition to the fumes of burning sulphur.

Were it not for the expense, hydrogen peroxide would be the ideal bleaching agent for the animal fibers.

#### PRINTING

A great variety of colored designs are produced on the loom by using different colored warp and filling yarns and different weaves, but in all these the designs are easily made only in somewhat rectangular patterns.

Print goods have doubtless evolved from the decoration of fabrics with the brush. Block printing was first used, the design being engraved in relief on blocks of wood. These are dipped in the colored paste, spread thinly, and applied to successive portions of the cloth by hand. These blocks are now replaced in the printing machine by engraved copper rolls, the design being such that it is repeated once or a number of times in each revolution of the cylinder. There is a printing roll for each color of the design. Sometimes both the background and the design are printed on the cloth, but the more common process is for the design only to be printed on the cloth which may be dyed afterwards. In the paste of the printed design there

**Block and  
Machine  
Printing**

is some chemical which prevents the portions printed from taking the dye, consequently these remain white or a different color. This is called the "resist" process. Another process is to first dye the cloth and then print on some chemical which, when the calico is steamed, discharges the color. This is called the "discharge" process. Sometimes this weakens the goods in the places where the color has been discharged.

**Fixing  
the Print**

The color paste used for printing contains both the dye and the mordant. After the calico has been printed it is steamed to develop and fix the color, washed, sometimes very slightly bleached, to clear the whites, and usually given a sizing of starch or gum, and then pressed and dried by passing over slowly revolving, steam-heated drums.

In general print goods are not so fast to washing and to light as those that have been dyed in the regular way, although the better grades are reasonably fast.

Prints are sometimes made in imitation of the more costly gingham or other goods in which the color design is made in the weaving. It is easy to detect the imitation as the design of printed fabrics does not penetrate to the back of the cloth.

**Warp  
Printing**

Sometimes the warps are printed before the cloth is woven, thus giving very pretty indefinite designs, especially in silk.

**FINISHING**

The finishing of woolen and worsted goods has much to do with their appearance. No cloth comes from the loom in a perfect condition, therefore inspection is the first process. Loose threads and knots are carefully cut off by the "burler" and imperfections in the weaving rectified by the "menders." The goods may now be singed and sheared.

**Burling  
and  
Mending**

Woolens, and sometimes worsteds, are next "fulled" or felted by being run round and round in a machine while moistened with soap. The friction of the cloth on itself produces some heat which, with the moisture and soap, causes the goods to shrink in length and width while increasing in thickness. During this process, "flocks" are often added, especially for smooth finished woolen goods. These flocks are fine fibers of wool obtained from the shearing machine or made by cutting up old woolen cloth. They are felted with the fibers of the goods and add weight and firmness.

**Fulling****Flocks**

After the fulling, the goods is washed to remove the soap, dyed, if desired, and often "speck dyed" with a special dye which colors the bits of burs, remaining in the cloth, but not the wool. The next process is the "gigging" which raises the nap. The cloth is run close to rapidly revolving "teazels" and also may be run through a napping machine. It may be sheared again and then steamed and pressed. This is but a brief outline; there are generally more processes.

**Raising  
the Nap**

Woolen cloth coming from the loom may be so

treated in the finishing room as to produce fabrics entirely different in appearance. One of the chief objects of the finishing is to give to the cloth as fine an appearance as possible to attract the buyer. Much of the fine finish disappears through wear, especially with inferior goods made from poor materials. The wearing quality of the goods is primarily dependent upon the strength and quality of the fibers of which it is made, so that the yarn of the filling and the warp should be examined when selecting materials. In general, hard twisted yarn will give the better wearing cloth.

## FABRICS

The present day shops offer such a great variety of fabrics that only a few of the most important can be mentioned here.

### COTTON GOODS

Cotton is cool and heavy, is a non-conductor of heat, crushes easily, but like all vegetable fibers it may be laundered without injury to the fibers. Cotton does not take the darker dyes as well as animal fibers and for this reason it does not combine satisfactorily with wool. As an adulterant it wears shabby and loses its brightness. It is only when cotton does not pretend to be anything else that it is our most useful and durable textile. The readiness with which cotton takes the lighter dyes and improved methods of ginning, spinning, and weaving have made cotton goods superior to any other for summer use.

Muslin, calico, and gingham must always head the list of cotton goods. Muslin is coarse and fine, bleached, unbleached, and half bleached, twilled or plain weave. Under the head of muslin brought to a high degree of perfection in weave and finish will be found dimity, mull, Indian lawn, organdie, Swiss, and Madras, and a host of others equally beautiful. Madras muslin has a thin, transparent ground with a heavily raised pattern woven of a soft, thick thread unlike the ground work. Waste is used for the pattern. Organdie muslin is soft, opaque, white, or colored, with

**Muslin**

raised dots of pattern and plain weave. Dimity has a fine cord running with the selva ge.

Gingham is a smooth, close cotton usually woven in checks or stripes. The yarn is dyed before being woven, making the cloth alike on both sides, and the weave is either plain or twilled. Ginghams are also woven of silk and cotton mixed or of silk and ramie.

Cretonne, chintz, dress linings, crape, velveteen, and lace are made of cotton.

Flannelette, which is woven to imitate flannel, is soft and light and is preferred by many who find woolen irritating. It does not shrink as woolen does and is made in beautiful, soft colors and the best grades do not fade. For nightdresses, underwear, and sheets, during cold weather this inexpensive fabric is unequaled.

Among the heavier cotton fabrics may be mentioned denim and ticking which are now printed in beautiful designs and colors and used for interior decoration as well as for clothing and bedding.

The great variety of fibers, the many different ways of preparing each for manufacture, the differences in the preparatory processes in spinning, weaving, or in any of the later processes of finishing produce the varied appearance of the finished product in cotton as in other fabrics.

#### LINENS

Linen is one of the oldest textiles; it was used by the early Egyptians for the priests' garments and for

the wrappings of mummies. Many housekeepers think that there is no material for sheets and pillow cases comparable to linen, but it is not an ideal dressing for beds, for in spite of its heavier body, it wrinkles and musses much more readily than good cotton. For table service, however, for the toilet, and for minor ornamental purposes linen has no equal. Its smoothness of texture, its brilliancy which laundering increases, its wearing qualities, its exquisite freshness, make it the one fabric fit for the table.

Table linen is woven plain and figured, checked and diapered. In the figured or damask cloth the patterns stand out distinctly. This is due to the play of light and shade on the horizontal and vertical lines. In some lights the pattern is scarcely noticeable. When buying a cloth, let it be between the observer and the light, for in this position the pattern will show to the best advantage. There is a certain amount of shade on all horizontal lines or of shadow cast by them, while the vertical lines are illuminated, thus although the warp and woof threads are of the same color, the pattern seems to stand out from the background.

Linen should not be adulterated. It should be for use and not for show, for use brightens and whitens it.

Linen adulterated with cotton becomes fuzzy through wear because of the much shorter cotton fibers. The tendency can often be seen by rolling the goods between the thumb and fingers.

**Table  
Linen**

Crash of different widths and quality furnishes tea towels, "huck," damask and other weaves come in various widths and may be purchased by the yard. Russia crash is best for kitchen towels.

#### WOOLENS AND WORSTEDS

##### Standard Goods

The many grades of wool with the great variety of weaves and finish make an almost infinite variety of woolen and worsted fabrics. New goods are constantly being put upon the market, or old goods with new names. Standard goods, such as serges, cashmere, Henrietta cloth, and covert cloth, are always to be found in the shops. These are all twilled goods. The serges are woven of combed wool and are harsh, tough, springy, worsted fabrics of medium and heavy weight, with a distinct twill, rather smooth surface, and plainer back. There are also loosely woven serges. Cashmere and Henrietta cloth have a fine, irregular twill—the finest made. They are woven with silk, wool, and cotton warp, but the latter gives an inferior textile.

##### Tweeds

Tweeds and homespun are names given to coarse cloth of which the wool is spun by hand and woven on hand looms. These goods vary according to the locality in which they are made. The wool is mixed without regard to color, the yarn being spun and twisted in the most primitive manner, giving the cloth an uneven, unfinished appearance. These are among the best wearing cloths on the market and are espe-



cially suitable for suits that will receive hard wear. Scotland and Ireland are famous for their tweeds and homespuns and what are known as the "cottage industries" have been recently revived in those countries as the products of their hand looms have become deservedly popular abroad.

The "Harris Tweeds," made on the Island of Lewis and Harris, north of Scotland, are in the old style by the "crofters." After weaving the goods are "waulked"—milled or felted—with the bare feet, accompanied by singing the waulking song and beating time with the feet. The dyeing is done in pots in the old-fashioned way and until recently the dyestuffs were obtained from mosses, lichens, heather, broom, and other plants. Now, however, some of the best aniline dyes are being used. A peculiar characteristic of the Harris tweed is the peat smoke smell caused by the fabric being woven in the crofters' cottages, where there is always a strong odor of peat "reek" from the peat which is burned for fuel. The ordinary so-called Harris tweeds sold in this country are made on the southern border of Scotland, in factories, and are but imitations of the real Harris tweeds.

**Harris  
Tweeds**

The light colored tweeds—natural color of wool—come from the island of St. Kilda. This island stands out in mid ocean, barren and wild, devoid of plants or shrubs of any kind for making dyes. The crofters content themselves without dyestuffs. The industry

is maintained by nobility to help the islanders and the fabrics are fashionable and high priced.

The foregoing represent the worsteds. Among the heavy woollens are covert cloth, a twilled fabric of hard finish and great durability, melton, doeskin, broadcloth and cassimeres. The light weight woolen goods are represented by crepe cloth, with crinkled, rough surface, nun's veiling, flannel, which is woven in many ways and given various names, wool canvas, and poplins. The list might be extended, but these fabrics are always to be found in the shops of good color and are the best of the all wool fabrics for wear.

**Mohair**

Mohair is a material made from the hair of the angora goat, woven with silk, wool, worsted, or cotton warp. It is a dust-shedding material, does not shrink, and bears hard wear well. Alpaca, on account of its

**Alpaca**

softness, elasticity, and exemption from shaggy defects, combines admirably with cotton in the manufacture of fine goods, which attains almost the glossy brightness of silk. The yarn is used for weaving alpaca linings and light coatings for warm climates.

**SILKS**

Many silks can be washed without injury to the fibers, but they cannot be boiled without destroying the luster. Silks may be had in various widths and endless variety of weaves. Many are reversible.

**Loading  
Silk**

Silks are adulterated with cotton and ramie fibers. The chemicals used in "loading" or "dynamiting" to give the weight lost by cleaning or removing the gum

from the raw silk give to the cheaper grades the stiff, harsh feeling and cause the splitting and cracking of the silk, hence the quality of the fiber should be considered when selecting a silk, not the weight. Taffeta is often heavily loaded.

Foulard and surah are twilled silks. Corded silks are woven with a cord running from selvage to selvage. To this class belong the grosgrains, Ottoman, faille Francaise—a silk resembling grosgrain, but softer and brighter. Irish poplins and bengalines have wool for the filling instead of silk.

Great improvement has been made in the manufacture of wash silks. They are fine in color and have a glossy surface. Pongee is a beautiful, durable silk in different shades of natural color. It is woven in different widths. This silk is especially valuable for underwear. The first cost is greater, but it outwears muslin or linen. It is also used for children's garments and for outside wraps. For many purposes, no better textile can be found.

Wash  
Silks

Crepe de Chine is an incomparable textile possessing as much softness as strength. It is always supple, never creases, launders well, and comes in the most beautiful soft shades as well as in black and dark colors.

Satin is distinguished by its glossy, lustrous surface, obtained in the weaving.

Piled fabrics are rich, thick materials made of silk, wool, mohair, and cotton, comprising the velvets, velveteens, plushes, corduroys, and wilton and velvet car-

Piled  
Fabrics

pets. The soft, raised pile is first woven in loops—Brussels carpet is a good example—and the loops are cut. The back of the goods is plain.

**Velvet**

Velvet has always and justly been regarded as the most beautiful of textiles. No matter how fashions change in regard to other materials, velvet never loses its vogue. For robes and cloaks, for mantles and jackets, for hats and bonnets, for trimming and decoration, velvet has been popular for a greater period than the life of any living mortal, but never before has it been so cheap, so varied and so beautiful as it is now. One can in the passing throng of pedestrians on any crowded street see the use and abuse of this noble material. There is scarcely an article of dress into whose composition it does not enter and it is worn upon all occasions. Many things have brought about this result. The tendency of fashion is towards the decorative and picturesque and in these qualities velvet excels all other fabrics. Silk waste and thread are cheaper than ever before so that velvet costs much less than formerly. The men behind the looms have evolved more designs and novelties in the making of velvet than has ever been known and colors beautiful in themselves are seemingly enhanced when applied to velvet.

**Velveteen**

All that has been said in favor of velvet applies equally as well to the best velveteen,—in fact it is a textile of even greater value and beauty than velvet. The best grades are not cheap, but they wear better

than silk velvet, are fine and silky, excellent in color and sheen, launder well, and do not press-mark as does silk velvet. Velveteen takes the dye so beautifully and finishes so well that it has taken rank with our best standard fabrics. It is made entirely of cotton. It varies in width but is always wider than velvet.

A knowledge of the various widths of textiles is important in buying. Transparent fabrics are usually wider than heavier goods made of the same fiber. Muslin is wider than calico or ordinary print, and thin silk fabrics such as mull and chiffon are wider than velvet.

**Widths of  
Fabrics**

In wool dress goods various distinct widths are known as single—thirty and thirty-six inches—double fold (forty-five and fifty-four inches), etc. Silk, velvet, and velveteen are single width. The velvet ranges from eighteen to twenty-four inches in width and velveteen twenty-seven. Bodice linings vary from thirty-five to thirty-eight inches; skirt linings come in both single and double fold.

Household linen including bedding varies in width from one yard to two and one-fourth and two and one-half yards for sheeting and from thirty-eight to fifty-four inches for pillow case muslin.

Table linen is woven in both square and circular cloths of various sizes, and napkins vary in width from the small sizes to a yard square.

No fixed widths can be given for any textile as width often changes with the weave.

## NAMES OF FABRICS

Textiles usually take their names from the country, city, port, or province from whence they originated; from the names of the makers; and methods of weaving, dyeing, ornamentation, etc. The fixing of localities, methods, etc., is oftentimes guesswork. The textiles of to-day bearing the same name as those of the middle ages have nothing in common. Buckram was originally made in and called from Bokkara. In the middle ages it was costly, fine, and beautiful, used for church vestments, veils for covering lecterns, cathedral flags, and in the 16th century for the lining of velvet gowns. The coarse, heavy, plain-woven linen or cotton material known as buckram today is used for stiffening, etc.

**Fustian** Fustian, a kind of corduroy or velveteen, was originally woven at Fustat on the Nile. The warp was stout linen, the woof of cotton so twilled and cut that it gave a low thick pile. Chaucer's knight in the fourteenth century wore fustian. In the fifteenth century Naples was famous for the weaving of fustians.

A cloth made in France at a town called Mustrevilliers was known as "mustyrd devells."

**Damaak** China is supposed to be the first country to weave patterned silks. India, Persia, Syria, and Byzantine Greece followed. Those were known as "diaspron" or diaper, a name given them at Constantinople. In the twelfth century, the city of Damascus, long famed

for her beautiful textiles, outstripped all other places for beauty of design and gave the Damascen or damask, so we have in modern times all fabrics whether of silk, cotton, wool, or linen, curiously woven and designed, known as damask, and diaper, which means pattern, is almost forgotten, or only a part of the elaborate design on damask. Bandekin, a costly cloth, took its name from Bagdad. Dorneck an inferior damask woven of silk, wool, linen, thread and gold, was made in Flanders at the city of Dorneck.

From the Asiatic city Mosul came the muslin used then as it is now throughout the world. So skilled were its weavers that the threads were of hair-like fineness. This was known as the invisible muslin, the weaving of which has become a lost art. To this beautiful cloth were given many fanciful and poetic names. It was woven with strips of gold and silver.

Muslin

Calico derives its name from the city of Calicut in India. The city is scarcely known to-day; it was the first Indian city visited by Europeans.

Calico

In the thirteenth century Arras was famous for its areste or tapestry, "the noblest of the weaving arts"; in it there is nothing mechanical. Mechanical weaving repeats the pattern on the cloth within comparatively narrow limits and the number of colors is in most cases limited to four or five.

Silks and cottons are distinguished through their colors and shades. Tarsus was a purple silk. Other cities gave their name to various shades, according as

they were dyed at Antioch, Alexandria, or at Naples. Watered or moire silk takes its name from the finish.

From "canabis," the Latin name for hemp or flax, we have the word "canvas" to mean any texture woven of hempen thread.

To this list of fabrics might be added many others of cotton, linen, wool, and silk with new names, closely resembling the old materials, having greater or less merit.

The following lists of fabrics and terms may be helpful for reference:

**Art linen**—With round, hard twisted threads.

**"Albert cloth"**—Named for England's prince, is a reversible all-wool material each side of different colors and so finished that no lining is required. It is used chiefly for overcoats and better known as "golf cloth," "plaid back," etc.

**Armure**—A cloth woven in miniature imitation of feudal metal armor plates, heraldic devices, diamonds, birdseye, and seeded effects.

**Astrakhan**—A woolen or silk material with a long and closely curled pile in imitation of the fur from which it is named.

**Backed-cloth worsteds** or other fabrics which are woven with an extra layer of warp or other filling underneath the face, usually for increased weight and bulk.

**Batiste**—The French word for lawn, fine white cotton or linen fabric. Sometimes printed.

**Batting** or padding, cotton or wool prepared in sheets for quilting or interlining.

**Beaver**—Similar to Kersey, but with a longer nap, soft, thick nap inside.

**Bedford cord**—A closely woven woolen or cotton cloth having a raised corded surface similar to pique, used for women's suits.

**Bonde**—A loosely woven fabric with a curly, hairy surface, usually made with a jersey or stockinet body.



- Bourette**—An effect of weaving produced by fancy yarns showing in lumps at intervals over the face of the cloth; used for women's and children's suits.
- Beverteen**—A heavy cotton cloth used for men's hunting garments.
- Broadcloth**—A fine woolen cloth with a glossy finished surface, the better grades being woven with a twilled back. It takes its name from its width. It is used for men's and women's wear.
- Buckram**—A coarse, heavy, plain-woven linen or cotton material used for stiffening.
- Buckskin**—A stout doe skin with a more defined twill.
- Butternut**—The coarse brown twilled homespun cloth woven of wool prior to the Civil War—colored brown with dye from the butternut or walnut tree; used for men's wear and for decorative purposes.
- Cambric**—Fine white linen, also made in cotton in imitation.
- Camel's hair**—A beautiful, soft, silky fabric, usually woven like cheviot of hair of camel and goat.
- Canvas**—A linen, cotton, silk, or wool cloth of different weaves and widths, used for many purposes—clothing, as a background for embroidery, hangings, spreads, etc.
- Canton flannel**—A stout, twilled cotton cloth with a nap on one or both sides, used for clothing and decorative purposes.
- Cassimere**—A general term for all-wool fabrics woven either plain or twilled, coarse or fine, of woolen yarn. The pattern is always woven plain and distinct and the cloth is never napped.
- Castor Beaver**—A heavy, milled, face-finished, all-wool cloth lighter in weight than ordinary beaver.
- Chinchilla**—A thick, heavy, double woven fabric with a long napped surface curled up into little tufts in imitation of chinchilla fur; used for coats.
- Clan Tartan**—The plaids of the various highland clans of Scotland.
- Clay**—A name given to serges, worsteds, and diagonals woven after a process of J. & P. Clay of Huddersfield, England.
- Coating**—Those woolen and worsted fabrics most especially adapted to men's dress and overcoats.

- Corduroy**—A thick cotton pile material, corded or ribbed on the surface; used for men's, women's, and children's wear.
- Corkscrew-worsted goods**—So-called from its fancied resemblance to the twists of the corkscrew.
- Cotton worsted**—All cotton or part cotton worsted-wove cloth.
- Cottonade**—Stout cotton cloth in imitation of woolen or worsted cloth; used for men's trousers.
- Covert**—A twill-woven cloth sometimes with full face, sometimes sheared to imitate whipcord.
- Crape cloth**—A stout worsted fabric with surface in imitation of silk crape, used for dress coats.
- Crash**—A strong, coarse linen cloth of different widths, used for towels, suits, table linen, hangings, bed spreads; in fact, there is no end to the uses to which this textile can be adapted.
- Cravenette**—Cloths treated and finished before weaving by an improved process which renders them rainproof. A secret process owned by the Cravenette Company and by Priestly & Company of England and the United States.
- Crepe**—A light weight silk, silk and wool, or all wool or cotton cloth of irregular weave.
- Diagonal**—A worsted cloth with prominent diagonal ridges.
- Doeskin**—A compact twilled woolen, soft and pliable.
- Drap D'Alma**—A fine, close, flat-ribbed, twilled fabric of wool or silk and wool, finished on but one side.
- Drap D'Ete**—A fine, light worsted fabric woven in longitudinal cords.
- Drilling**—General term for various twilled cotton stuffs used for lining, men's wear, and general purposes.
- Empress cloth**—A heavy dress goods with napped or corded surface, named for the Empress Eugenia; sometimes called Electrol cloth or Beretz.
- Etamine**—A light woolen cloth similar to batiste and nun's cloth, used for women's and children's wear.
- Faille Francaise**—A soft, lustrous silk of wider cord than grosgrain, but narrower than ottoman.
- Farmer satin**—A lining of cotton chain or warp and wool filling, finished with high lustre, also called Italian cloth.
- Flannel**—A soft, light weight woolen fabric of which the yarn is but lightly twisted, plain weave or twilled; used for clothing, etc.

- Flannelette**—A half cotton or all cotton flannel-like fabric.
- Frieze**—A thick, shaggy, heavy nap woolen overcoat cloth.
- Gingham** was first manufactured in Gongsamp in France and was known as Madras gingham. Seersucker gingham was originally a thin linen fabric made in the East Indies. Zephyr gingham is a soft fine variety of Scotch and French gingham, are superior qualities, heavier in weight.
- Fur Beaver**—A long napped cloth imitation fur.
- Grass cloth**—A fine, smooth, linen woven in checks of blue and white, red and white, etc., used for dish towels; also a thin dress material of ramie and cotton, etc.
- Grenadine**—A thick silk gauze, either plain with a solid design or pattern upon it or combined in stripes with other weaves, as satin, moire, etc.
- Grosgrain**—A close-woven, finely ribbed or corded silk with but little lustre.
- Haircloth**—A cloth woven of horse hair, from which it takes its name, for weft with cotton or linen warp; used for facings, linings, furniture cover, etc.
- Holland**—A stout, plain-woven, unbleached, linen cloth used for linings, window shades, etc.
- Homespun**—A cloth woven on hand looms or made in imitation of such cloth for both men's and women's wear.
- Hop-sacking**—A plain woven canvas dress fabric of wool.
- Huchaback**—A corruption of huckster-back, meaning originally pedler's ware—Toweling made of all linen, linen and cotton, cotton and wool, either by the yard or as separate towels; the part wool huck always separate towels.
- Irish linen**—Full bleached, fine, plain woven linen used for shirts, collars, cuffs, etc., of different widths.
- Jersey cloth**—Woolen stockinette.
- Kaikai**—A thin Japanese silk.
- Kersey**—A heavy, closely woven cloth with a smooth face and glossy finish.
- Kerseymere**—A fine, twilled, woolen cloth of peculiar texture, one thread of warp and two of woof being always above.
- Khaki**—A light, yellow-brown colored cotton cloth used for army service in hot countries.
- Ladies' cloth**—A fine, wide, wool flannel, slightly napped, similar to broadcloth.

- Lusterine**—A thin, twilled, cotton lining finished with high lustre in imitation of silk.
- Marseilles**—A sort of figured pique, used for women's and children's clothes and for men's coats.
- Matelasse**—A silk and wool or all wool brocade, usually for coats.
- Melton**—A stout woolen cloth, fulled, sheared, and finished without a nap; like Kersey, but without a gloss.
- Merino**—A thin woolen fabric made of the fine wool of the marion sheep, generally used for women's and children's wear, vestings, and underclothing.
- Mohair**—A shiny fabric of great durability, made from the wool of the Angora goat; used for both men's and women's clothing.
- Moire**—The water effect produced on silk, moreen, and like fabrics. The finest watered silks are known as Moire Antique. Moreen is a woolen or mixed fabric to which the same process has been applied.
- Moleskin**—A medium heavy twilled cotton cloth, napped inside; used for men's wear and ornamental purposes.
- Muslin**—A cotton fabric of various classes and names; bleached and unbleached, half bleached, cambric, book muslin, long cloth, mull, organdie, lawns, etc.; used for all purposes.
- Nankeen**—A peculiar fabric of a pale dull yellow or orange color, woven out of the fibrous tissue which lies between the outer and sap-wood of a tree or shrub that grows in the East Indies and especially in China. The name is derived from the city of Nankin. An imitation is made out of cotton, colored with Annato. The genuine nankeen is never more than eighteen or twenty inches wide and is used for light summer clothing.
- Overcoating**—Fabrics woven especially for overcoats—covert, kersey, melton, beaver, frieze, vicuna, whipcord, cheviot, chinchilla, etc., made of both wool and worsted.
- Pique**—A heavy cotton cloth having a surface that is corded or having a raised lozenge pattern; used for women's and children's suits, men's vests, etc.
- Prunella**—Lasting cloth.
- Sateen**—A close twilled cotton fabric; soft and glossy, used for lining.



- Satin—A silk fabric having a high lustre on its face.
- Satinet—A cheap clothing material similar to cassimere, made with a cotton warp and a filling of short, inferior, shoddy wool which is mixed with enough long wool to enable it to be spun and woven in a way to bring that filling to the surface of the cloth; afterwards fulled, sheared, and the pattern printed on the face.
- Serge—A lining of cotton or linen warp and a wool or mohair filling, woven three-leaf twill.
- Serge—A fine, diagonal, twilled, worsted—both all worsted and with a worsted warp and woolen filling; used for men's and women's suits.
- Shetlands—Very shaggy overcoatings, named from the Shetland pony, the coat of which it is supposed to imitate in appearance.
- Shoddy—Waste thrown off in spinning—shredded rags, and bits of cloth manipulated into new cloth.
- Sicilian—A mohair fabric.
- Silesia—A light, close-woven, fine twilled cotton fabric used for dress linings, etc.
- Stockinet—A plain, elastic texture made on a knitting frame, used for underwear, etc.
- Surah—A twilled silk similar to serge; first made in Surat, India.
- Tricot—A double-twill cloth having both a warp and filling effect.
- Tweed—Much like homespun in appearance, both being either twilled or plain. They are made from rough worsted yarn spun at home. In tweed the yarn is harder twisted, giving a more distinct twill. It is generally more compact, less rough, and better finished than homespun.
- Uniform cloth—Cloth suitable for uniforms, usually a stout, fulled, woolen cloth, similar to kersey.
- Venetian—A cloth milled and cropped bare in finish.
- Vicuna—A soft twilled cloth similar to cheviot, made of the Andes vicuna, hence its name.
- Whipcord—A worsted cloth having a small, prominent twill.
- Yacht cloth—A flannel heavier than ordinary serge or flannel.
-

- Cord**—The general term is applied to any fabric in which the lines run in the same direction as the selvage.
- Count**—In spinning, the number given to any thread or yarn, except silk, to indicate its relative fineness, based on the number of yards required to weigh one pound.
- Felt**—A cloth of wool, hair, fur, etc., not woven, but felted together; used for hats, slippers, boot tops, etc.
- Flock**—Finely divided woolen waste used in finishing cheap woolens.
- Kemps**—Fibers of hair like structure that sometimes come in wool, always in goat hair. They do not take the dye.
- Mercerized**—A term applied to cotton fabrics of which the yarn is chemically treated with a strong solution of caustic soda, giving the appearance of silk, more or less permanent; named after Mercer, discoverer of the process.
- Mill ends**—Trade term referring to short lengths, seconds, damaged pieces, etc., of cloth, embroideries, etc., that accumulate in mills and shops and are usually sold at a nominal price.
- Narrow cloth**—Trade term for fabrics less than 29 inches wide. Wider cloths are called broad cloths.
- Oil-boiled**—Trade term for colors so treated to insure permanence.
- Oiled silk**—The plain silk boiled in oil. Silk boiled in oil and dried, becoming translucent and waterproof; used as a perspiration guard.
- Pepper-and-salt**—A black and white or grayish mixture, effected in weaving.
- Rubber cloth**—Usually cotton sheeting or drilling with a coating of rubber on one side; used as protective cloth for various purposes.
- Shepherd check**—Tiny checks, usually black and white.
- Twilled**—Woven in such a manner as to produce lines or ribs diagonally or across the surface of the fabric.
- Woolens**—Name of fabrics of carded wool, usually soft woven.
- Worsteds**—Fabrics made of combed wool, usually hard woven. The combing is the process of arranging the fibers of wool, mohair, cotton, linen, into a parallel condition, preparatory to spinning into a smooth, even and regular yarn. The perfected application of the combing principle.

## BIBLIOGRAPHY ON TEXTILES

### Historical and Art

Arts and Crafts Essays .....	\$1.00
Morris, Crane, et al. .....	Postage .10
Colonial Days in Old New England .....	1.25
Alice Morse Earle. .....	Postage .12
The Primitive Family .....	1.25
Starcke. .....	Postage .12
Man Before Metals .....	1.75
Joly. .....	Postage .14
Origin of Inventions .....	1.50
Mason. .....	Postage .16
Woman's Share in Primitive Culture .....	1.75
Mason. .....	Postage .16
Textiles—The Lesser Arts .....	1.00
William Morris. .....	Postage .10
Industrial Evolution of the United States .....	1.25
Carroll D. Wright. .....	Postage .16

### Technical Books

Through a special arrangement with the American School of Correspondence we are able to lend or sell to our students some of their textile books, which are technical though simple. Price 50 cents per part, postage 4c.

Textile Chemistry and Dyeing. 4 Parts.

    Part I. Textile Fibers.

    Part II. Bleaching.

    Part III. Mordants and Natural Dyes.

    Part IV. Artificial Dyestuffs.

Cotton Fiber.

Cotton Spinning. 5 Parts.

Weaving. 3 Parts.

Textile Design. 5 Parts.	
Woolen and Worsted Spinning. 4 Parts.	
Woolen and Worsted Finishing. 4 Parts.	
Textile Fibers .....	\$3.50
Mathews.	Postage .16
Textile Fabrics .....	.90
Rock.	Postage .08
Dyeing of Textile Fabrics .....	1.75
Hummell.	Postage .12
Bleaching and Calico Printing .....	4.00
Duerr.	Postage .14

*Note.*—Books may be ordered through the School or may be borrowed by members for one week. Send postage with request.

#### U. S. Government Publication

*Free* of the Department of Agriculture, Washington, D. C.:

- Flax for Seed and Fiber, Farmers' Bulletin No. 27.
- Cotton Seed and Its Products, Farmers' Bulletin No. 36.
- Raising Sheep, Farmers' Bulletin No. 96.
- The Angora Goat, Farmers' Bulletin No. 137.
- Silk Worm Culture, Farmers' Bulletin No. 165.
- Essential Steps in Securing an Early Crop of Cotton,  
Farmers' Bulletin No. 217.
- The Cotton Seed Industry, Reprint No. 239.
- The Hemp Industry in U. S., Reprint No. 254.
- Improvement of Cotton by Seed Selection, Reprint No.  
279.
- The Growing of Long-Staple Upland Cotton, Reprint  
No. 314.
- Principal Commercial Plant Fibers, Reprint No. 321.



*For sale* by the Superintendent of Documents, Washington,  
D. C. Send coin or money order,—stamps not accepted:

Sheep and Wool, Report No. 66, Office of the Secretary.  
Price 5c.

The Cotton Plant: Its History, Botany, Chemistry, Enemies, and Uses. Bulletin No. 33. Office of Experiment Stations. Price 60c.

Cotton Culture in Egypt. Bulletin No. 42. Price 5c.

OFFICE OF FIBER INVESTIGATIONS.

Uncultivated Bast Fibers. Report No. 6. Price 10c.

Cultivation of Ramie. Report No. 7. Price 10c.

Culture of Hemp and Jute. Report No. 8. Price 10c.

Fax Culture for Seed and Fiber. Report No. 10. Price

10c.

## **TEST QUESTIONS**

The following questions constitute the "written recitation" which the regular members of the A. S. H. E. answer in writing and send in for the correction and comment of the instructor. They are intended to emphasize and fix in the memory the most important points in the lesson.

## TEXTILES AND CLOTHING

### PART I

---

*Read Carefully.* Place your name and address on the first sheet of the test. Use a light grade of paper and write on one side of the sheet only. Leave space between the answers for the notes of the instructor. *Answer every question fully.* Read the lesson paper a number of times before attempting to answer the questions.

---

1. Give a brief outline of the craft of spinning, primitive and modern.
2. Outline the same for weaving.
3. Describe the hand loom.
4. Describe the cotton fiber. What kinds are there?
5. Who invented the cotton gin and how did this invention affect the cotton industry?
6. Give the chief characteristics of wool. Name the wool and fur bearing animals. How does wool differ from hair?
7. Trace briefly the preparation of wool from the fleece to the finished product.
8. Describe flax and outline the method for the preparation of the fibers. What is the name of the manufactured product of flax?
9. Name some other bast fibers and their products?
10. How do the textile fibers compare in the raw state in condition and price?
11. Give a brief description of silk from the egg to the woven cloth.

*TEXTILES AND CLOTHING*

12. (a) What is the chief constituent of the vegetable fibers? (b) How does their affinity for dyestuffs compare with wool and silk? (c) How do the alkalies affect wool?
13. Describe the principal weaves and give examples of each.
14. (a) How are cotton and flax bleached? (b) What is a mordant? (c) How should material be prepared for dyeing? (d) State what you know about old time methods of dyeing.
15. How are print goods made? Name some printed fabrics.
16. Define woolens and worsteds.
17. Describe the finishing of woollen and worsted cloths.
18. What is noil; shoddy; felt; flocks?
19. With what dress goods have you had experience, and with what results?
20. What factors determine the use of fabrics?
21. Of what value is the study of textiles? What have you gained by the study of this lesson?

*Note.*—After completing the test sign your full name.

# Textiles and Clothing

## Part II



#### EMBROIDERED INITIALS

*W* and *L*—Sewed on initials; *B*—Satin stitch in wreath of feather stitches; *C*—Outline and seed work; *D*—Chain and French knots; *H*—Cross stitch; *L*—Chain; *H*—At the right, and the cross stitch *H* are made over canvas and the canvas threads drawn.

# TEXTILES AND CLOTHING

## PART II

---

### HAND SEWING

Good sewing, good pressing, well finished ends and corners, lightness of touch which holds the work without apparently touching it, thus giving to the finished garment a fresh look—all these are important considerations.

The sewing done on wool, silk, and dresses of all kinds differs from that on underwear and white work. Muslin underwear requires frequent washing and ironing, hence the first essential is durability; close, small stitches, all raw edges carefully turned and stitched securely. Seams that are to come close to the body should lie perfectly flat. A round seam would wear out sooner by coming into frequent contact with the washboard and iron, besides irritating the skin. In dressmaking, unless the stitching is used for ornamental purposes, it should never show on the outside.

Periods of beautiful and dignified costume have been periods of fine needlework—one art leading to and helping on the production of the other.

Stitches may be divided into plain and ornamental. The plain stitches are the (1) basting, (2) running, (3) the running and back stitch, (4) half back stitch, (5) back stitch, (6) overhand or whipping stitch, (7) overcast, (8) hemming, and (9) blind or slip stitch.

**Kinds of  
Sewing**

**Plain  
Stitches**

**Ornamental  
Stitches**

The ornamental stitches most frequently used are (1) outline, (2) chain, (3) cat or herringbone, (4) blanket or loop, (5) feather, coral or briar, (6) hemstitching, (7) French knots, (8) button hole, and (9) cross stitch. Excepting the cross stitch, these are all variations of the plain and button hole stitches.

The plain stitches may be used for ornamental purposes. The basting stitch is known as Queen Anne darned work. The back stitch, known as "seed work," is used in embroidering letters and monograms. The overhand stitch is used as an ornamental stitch for joining selvages and in hemming. The chain stitch, besides being ornamental, makes one of the best darning stitches, reproducing the stitch in knitting. The cat stitch is also useful in binding down open seams for flannel hems, patching, etc.

**Basting**

(1) Basting proper is used only in the preparation of work to hold the stuff and lining, or any two or more parts of the work together while it is being stitched, none being left in the finished garment. It is also used as a guide for sewing, feather stitching, etc.

**Tucking**

The slanting basting stitch or "tacking" is used in dressmaking for holding linings. The needle is pointed towards the worker. Even basting is used for holding several thicknesses of cloth and if the garment is to be fitted, the stitches should be placed rather close. Uneven basting is used for hems and seams to be machine stitched. Several short stitches with one long one are



used to baste crape and wiry fabrics, for this method holds them better than stitches of equal length.

All basting should be fastened at start with a knot or knot and back stitch and finished with two or three back stitches. The length of thread may be broken or

**Fastening  
the Thread**

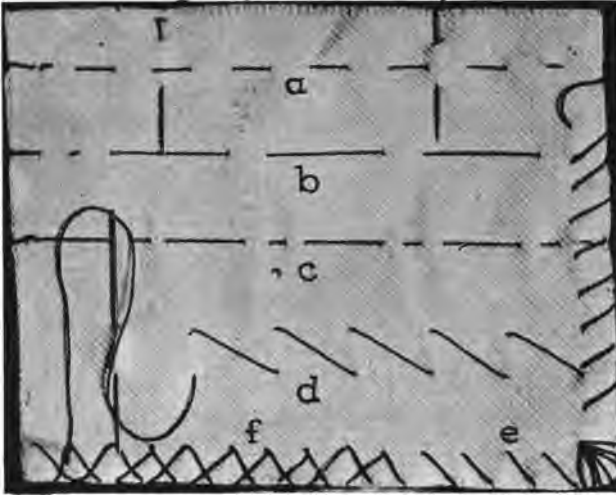

**BASTING STITCHES**

*a*—Even; *b*—Uneven; *c*—For wiry fabrics; *d*—Tacking; *e*—Overcasting; *f*—Double or tailor overcasting.

cut from the spool, but should always be cut from the work. Breaking weakens the fastening and biting off soils delicate work with the moisture from the breath, to say nothing of the injury to the teeth. Basting for large work should usually be done with the goods lying flat on the sewing table.

**Drawing  
Basting  
Threads**

For ordinary work, basting threads should be cut every few inches and drawn out. In velvet, every alternate stitch should be cut and drawn out on the right side with the pile of the goods. In the basting for velvet where the slanting stitch is used, only one end of the stitch touches the line of the seam—the rest is on the outside of the seam. Silk thread should be used



**POSITION OF THE HANDS IN RUNNING**

to baste velvet and gauze; fine thread should be used for basting delicate work.

**Running  
Stitch**

(2) Running is closely related to basting. It is not used for any seams that have to bear great strain, but for joining seams in this material, gathering, tucking, making cords, etc. The stitches are usually of equal length on both sides. Take one stitch in the seam and hold the goods between the thumb and first finger of each hand, as shown in the illustration, with the back of the thimble on the eye of the needle. Then, with as free wrist motion as possible, run or shake the needle through the material. The motion of the hand should come from the elbow joint.

Gathering, gauging, casing, etc., are used for drawing up the fullness of skirts, ruffles, flounces, etc., into a given space. The running stitch is used for these.

For gathering, the cloth is held in the same manner as for running. The needle, ordinarily, need not be taken out of the work, the stitches being pushed back over the eye as they are made; but for running long skirt seams in delicate material which would crinkle at the line of sewing and roughen the seam, the needle should be drawn through and the line of sewing smoothed on the thread at each needleful of stitches.

**Gathering**

Never use a double thread for gathering, as it is apt to knot, but put in two lines of gathering threads—one a full one-eighth of an inch below the other—and slip the stitches along the needle as described above. This method is a saving of time in the end. When the gathering threads are in, remove the needle, place a pin vertically close to the last stitch, and wind the thread around it a few times in the form of a figure eight. Use a coarse needle for stroking. Hold the work between the thumb and fingers of the left hand with the thumb on the gathering threads. To place the gathers, put the point of the needle *under* the lower gathering thread and press the plait or gather under the thumb, drawing the needle down, or simply pressing on the needle. Care must be taken not to scratch or tear the material. Continue entirely across the gathers, putting the needle under each stitch and holding the plait firmly between the thumb and finger: turn

**Stroking**

the material and stroke the *upper* edge of the gathers.

**Gauging**

The gauging stitch is usually longer on the face than on the back, draws the material up into distinct plaits, making it easy to dispose of the fullness neatly, regularly and securely by overhanding the top edge of each plait to the bottom edge of the band. The right side of the skirt and the right side of the belt are placed against each other and each gather oversewed to the belt. The space into which the material is to be gathered determines the length of the long stitch. The succeeding rows of stitches should be *directly* under those of the first.

**Running  
and Back  
Stitch**

(3) The running and back stitch is made by taking a few running stitches, drawing out the needle and making a back stitch over the last running stitch to strengthen the seam. Care must be taken not to hold the side next the worker too full and not to miss the under material, but to take the stitches even on both sides.

**Half Back  
Stitch**

(4) The half-back stitch is made by taking one stitch and placing the needle half way back, then bringing it out twice the length of the stitch and placing the needle half way back each time from where the last stitch ended. The appearance on the right side will be of regular space as in the running stitch.

**Back  
Stitch**

(5) The back stitch is made by placing the needle back to the last stitch, bringing it out once the length of the last stitch, then placing the needle back into the

last stitch, and so on, making the stitches follow each other with no space between. This is used in places that are to bear great strain as in sewing in sleeves.

(6) Overhanding, oversewing, whipping, top sewing are one and the same—small stitches taken over

**Whipping  
Stitch**

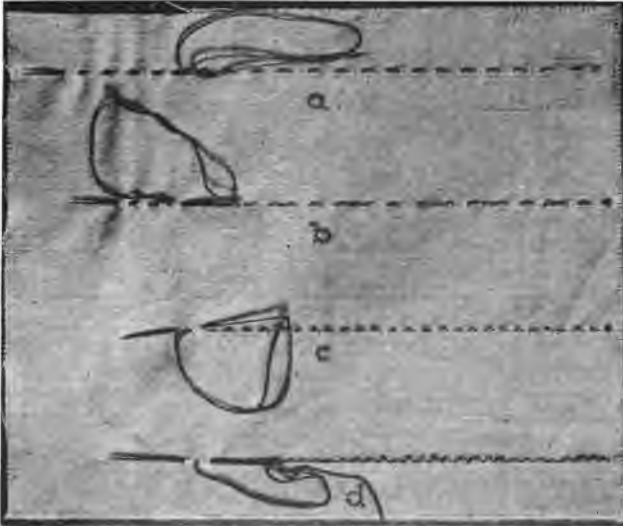

#### PLAIN STITCHES

*a*—Running; *b*—Running and back; *c*—Half back; *d*—Back stitch.

edges, to join folded edges or selvages, for sewing bands on gathers, sewing lace and insertion, and for sewing carpet strips together. The pieces for an overhand seam should be pinned carefully, placing the pins at right angles to the edge. The folded edges or selvages are placed together, the right side of the goods

being in. Do not use a knot to begin sewing, but leave the knot end of the thread and sew it in with the first stitches, carrying the thread on top of the seam. To finish off the seam, overhand back over the last few stitches.

**Position in  
Overhanding**

In sewing this seam, the goods should be held between the thumb and first finger of the left hand parallel with the chest, not over the end of finger. Point the needle towards the left shoulder, thus giving a slanting stitch. Care should be taken not to pucker or draw the seam. When the seam is finished, it should be opened and pressed flat.

**Overcasting**

(7) Overcasting is a slanting stitch used to keep raw edges from ravelling. This stitch, like oversewing, may be worked from right to left or from left to right.

The hem stitch and blind or slip stitch will be considered under hems.

**ORNAMENTAL STITCHES**

Never use a knot in any embroidery, but start by running a few stitches along the line which is to be covered.

**Outline  
Stitch**

(1) The outline stitch is the simplest of all embroidery stitches. Take a long stitch on the surface, with the needle pointing towards the chest in the line to be covered, and a short back stitch on the under side of the material. The effect of the under or wrong side of the material is exactly that of an ordinary back stitch. The beauty of this stitch depends upon its

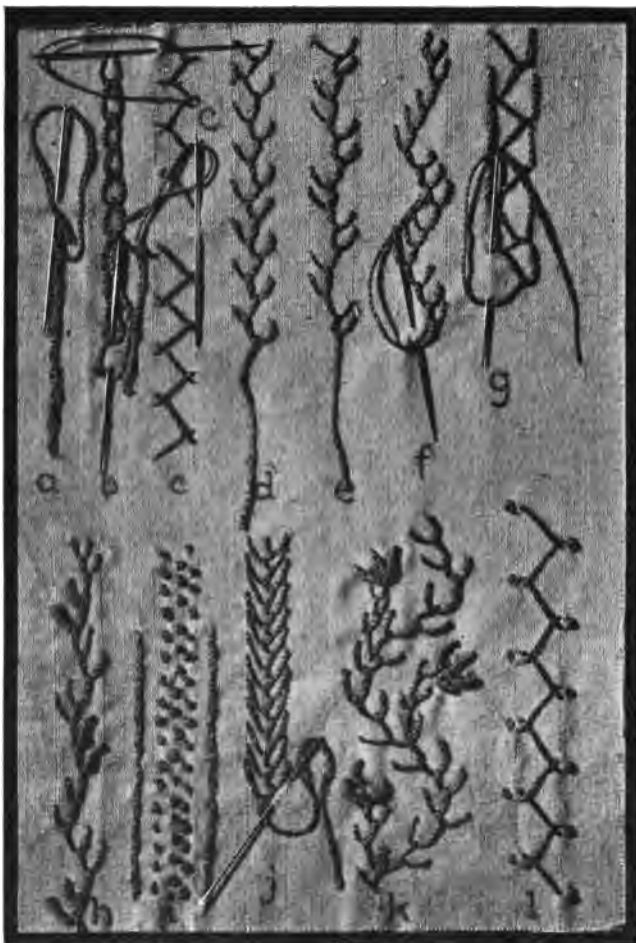

#### ORNAMENTAL STITCHES

*a*—Outline; *b*—Chain; *c*—Cat; *c'*—Catch; *d*—Single Feather; *e*—Double Feather; *f*—Tripple Feather; *g*—Modified Feather; *h*—Double Feather with Knots; *i*—French Knots and Outline; *j*—Herrine Bone; *k*—Fancy Feather; *l*—Catch Stitch with French Knots.

regularity and in always keeping the thread on the same side of the needle.

**Chain  
Stitch**

(2) The chain stitch when perfectly done should look like the stitch made by a single-thread machine. This stitch is made by taking the thread toward the worker, and before the needle is drawn out of the cloth the thread is held by the thumb under the point of the needle, as in a buttonhole, making a loop. The needle is inserted in the last loop for the next stitch. The chain stitch is used in modern embroidery as an outline and for darning, but in old embroidery, the outline and chain stitches were used for filling as well. They are found in Persian, Indian, and Italian Renaissance work. Like the feather stitch, the chain stitch is worked towards the worker.

**Cat  
Stitch**

(3) The cat stitch or herringbone stitch is an alternate slanting back stitch, the needle being placed first to the right and then to the left. This stitch must be worked evenly to be effective. It is used to finish flannel seams and hems, fasten down linings, opened seams, and canvas facings and featherbone, in millinery—in fact, this stitch is one of the most useful in sewing. The *catch* stitch is a variation of the cat stitch. Instead of pointing the needle towards the chest, the stitch is taken parallel with the chest. It is used for about the same purposes as the cat stitch. As with the outline stitch, the cat stitch is worked *from* the worker.

**Loop  
Stitch**

(4) Blanket or loop stitch, used to ornament the edge of blankets, etc., and for finishing the edge of



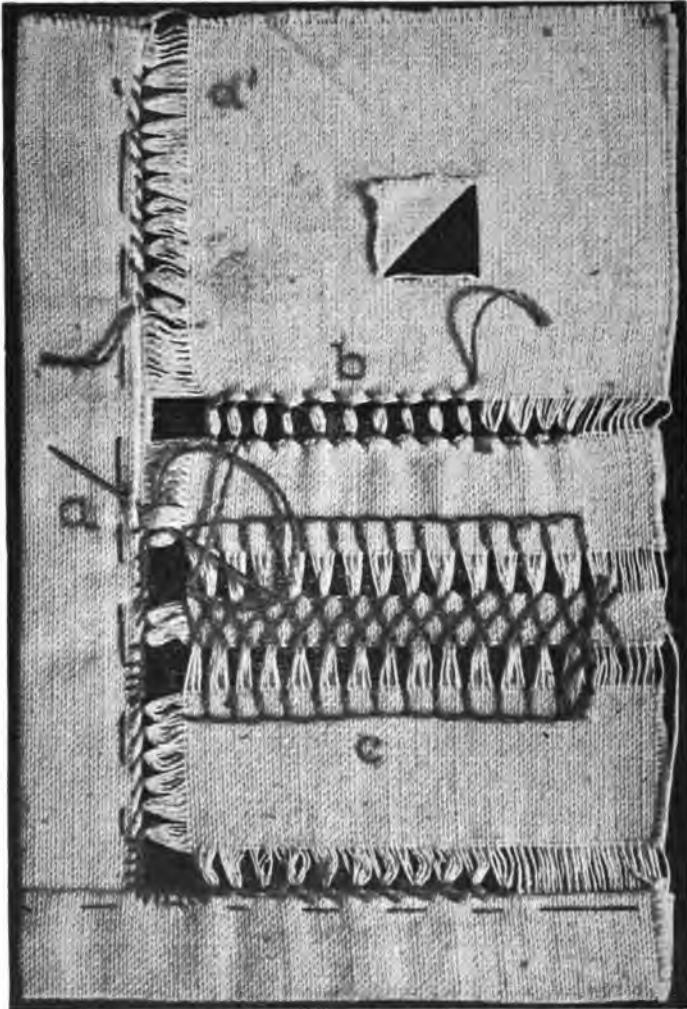

#### HEM STITCHING

*a*—Position of Needle; *a'*—Finished Hem Stitch; *b*—Ladder Stitch; *c*—  
 Example of Drawn Work Finished with Loop and Cat Stitches.

stockinet or web material, is worked from left to right, the edge of the material being held towards the worker. Start with three or four running stitches along the edge so the line of stitching will cover them. Insert the needle the desired width from the edge, draw it towards you down over the thread, being careful not to draw the thread too tightly over the edge of the flannel. Fasten the thread by taking running stitches under the last blanket stitch on the wrong side.

**Feather  
Stitch**

(5) Single, double, and triple feather or coral stitches may be made very ornamental and are used in all kinds of sewing and on all materials. They are always made towards the worker, the stitches being taken alternately to the right and left of the line of the design. The thread should always be carried under the needle as in a buttonhole stitch. The design may be varied by taking the stitches diagonally or straight, by making them close or separated, etc.

**Hem  
Stitch**

(6) Hemstitching is used for ornament in making hems and tucks. The first step in hemstitching is the drawing of threads. Rubbing the cloth along the line of threads to be drawn will make the drawing easier if the cloth is sized. After the threads are drawn, the hem is turned and basted even with the lowest edge of the drawn space. Insert the needle into the edge of the hem and material, taking up a cluster of threads bring the thread under the needle to form a buttonhole stitch or make a simple stitch in the edge of the fold. The number of threads drawn and the number in a cluster must be determined by the coarseness or fine-

ness of the material, the greater number being drawn and taken in fine material. There are several methods of hemstitching, but the results are about the same.

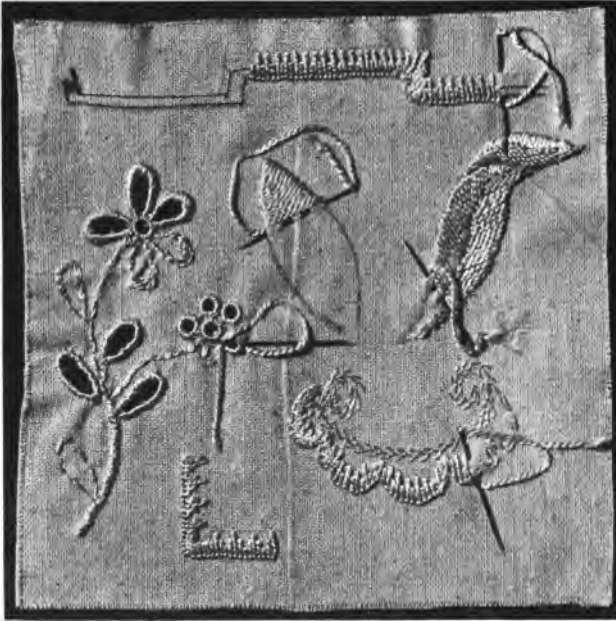

#### EMBROIDERY STITCHES

Eyelet Embroidery, Embroidery Button Hole, Flat Satin Stitch.

(7) French knots are used in connection with other stitches for borders enclosed in outline and chain stitches, in initials, centers of flowers, and as a filling-in stitch. The simplest method is of taking a small back stitch, bringing the thread from the *eye* of the needle under the point from right to left and drawing

**French  
Knots**

the needle perpendicularly from the cloth. Place the needle back of the knot and bring the point out in the place where the next knot is to be made. The size of the thread will determine the size of the knot.

**Embroidery  
Buttonhole**

(8) The embroidery buttonhole stitch has many possibilities and many variations. It is worked from left to right instead of from right to left as in a buttonhole. The thread from the work is carried under the point of the needle from left to right, just the reverse of the buttonhole. This stitch is used on flannel and in embroidery of all kinds; it may be padded or worked flat and the stitches may be taken a distance apart or near together.

**Cross  
Stitch**

(9) The cross stitch is worked on linen, scrim, canvas, or any open-meshed material. If done on a flat, smooth surface, it will be necessary to work over canvas, afterwards drawing out the canvas threads. The canvas should be well basted on the material, the warp threads of the canvas lying *perfectly straight* on a line with the warp threads of the material on which the pattern is worked. The stitches should always run the same way. If the first ground stitches are made from left to right, from bottom towards the top, the cross stitches should be made from right to left from the top towards the bottom. All the ground stitches run one way and the cross stitches in the opposite way.

This stitch is used for marking table linen, underwear, and embroidery designs. When marking linen and unlined work, make the under side very neat by running the thread under the stitches already made,

instead of taking a long stitch when beginning in another part of the letter or design.

(10) The satin stitch is an over and over stitch and is used on materials of all kinds for marking linen, etc.

Satin  
Stitch

The *padding* is the first step and should be done in long even stitches placed closely and over one another in the center. The size and proportions of the figure or letters determine the size of the thread. Fine thread gives the best results. The outline should be run

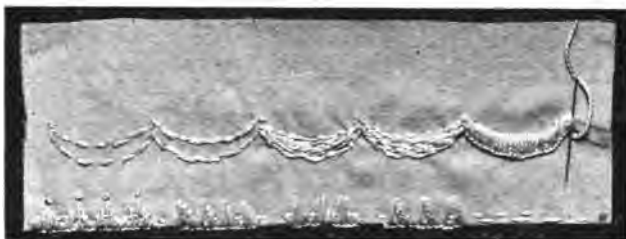

EMBROIDERY BUTTON HOLE AND BLANKET STITCHES  
Scallops Outlined and Padded.

twice; this keeps the edge firm. An even darning or basting stitches, chain stitches or outline stitch may be used if the space is not too small. The padding may be worked in an embroidery hoop to keep it smooth and even. Scallops may be padded in the same way or worked flat.

In large figures the stitches are laid closely and exactly parallel the entire length of the form. They may be straight across or at an angle, but the one slant must be maintained throughout. In small curved figures,

the stitches may be placed more closely at the inner edge and spread slightly at the outer edge. In flat work where the leaf or petal is large, two or three stitches taken in the cloth, back of the face stitch,

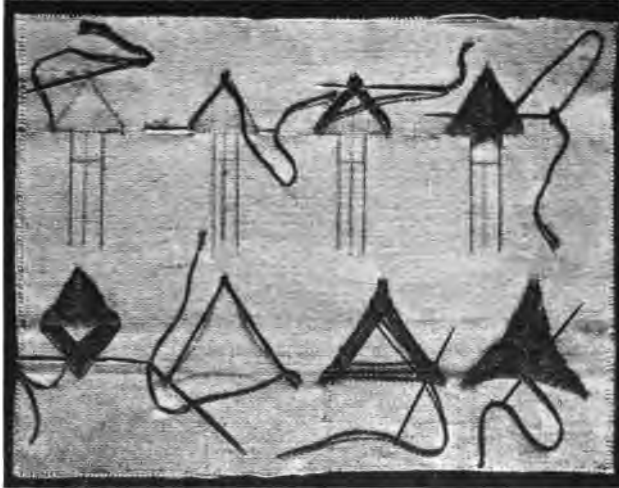

ARROW HEAD. DOUBLE ARROW HEAD AND CROW'S FOOT.

holds them even and prevents misplacement in laundering. (All embroidery should be ironed on the wrong side.)

**Eyelet  
Embroidery**

Eyelet embroidery is a simple over and over stitch forming a smooth, round edge. Like satin stitch, all outlines are run with an even darning stitch, except the very small eyelet holes, made with a stiletto. Long or oval openings must be cut through the center.

Shadow embroidery is worked on the wrong side of thin material, using the cat stitch. The outline of the design only shows on the right side, the body of the design being seen dimly through the material.

**Shadow  
Embroidery**

The arrow head and crow's foot are ornamental fastenings used in fine tailoring as endings for seams, tucks, plaits, and at corners. They are made as shown in the illustration.

**Arrow  
Heads**

Mercerized cotton, linen, or any of the embroidery silks can be used for these stitches, in all sizes and colors, or they can be worked with ordinary thread, cotton or linen, sewing silk, or twist. Cotton thread wears better than linen.

#### HEMS

A hem is a fold of goods twice folded to protect a raw edge. The first turn or fold of the hem is the most important. It should be straight and even, *folded to a thread*, for upon it depends the beauty of the hem. The hem should always be turned towards the worker and creased firmly, but never pleated along the fold. First crease the narrow fold, then crease the second fold the desired width, marking by a measure and baste not too near the edge. The first fold *along* the *woof* threads should be at least one-fourth of an inch in width. The woof threads give or stretch more than the warp threads; otherwise it will not lie flat.

**Folding  
Hems**

In sewing the hem, the needle should take up only the edge to be hemmed down and just enough to hold on the cloth or lining. In white work the stitches should be fine, showing as little as possible.

**Sewing  
Hems**

**Bias Hem** All bias and curved edges should have the first fold basted. In cloth or silk this first basting thread should match the material and not be taken out.

**Faced Hem** A facing or faced hem is also used as a protection to the edge of a garment. A true bias or fitted facing should be used for a facing if the edges of the garment are curved. An extension hem is one in which the whole width of the hem is used.

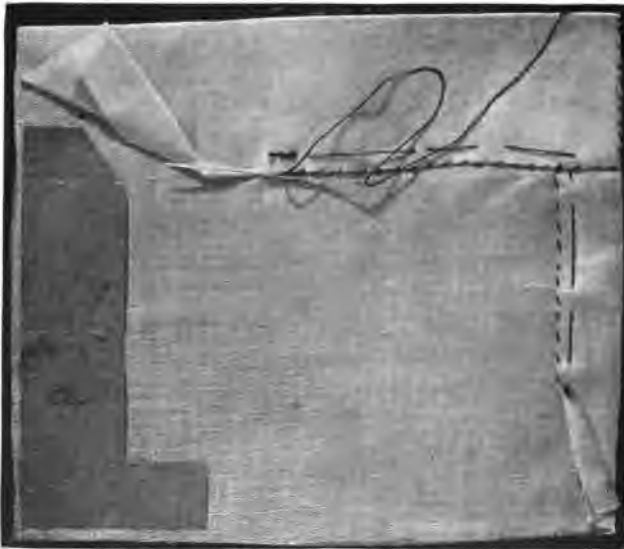

#### HEMMING

*a*—Shows method of cutting to do away with a clumsy corner.



Slip-stitching or invisible hemming is done on silk, wool, and thick material. The hem is pressed with an iron, a stitch as fine as possible is taken on the surface of the cloth and the needle slipped under and through the first fold, drawing the thread lightly. The needle and thread used in this stitch must be very fine.

**Slip-Stitching**

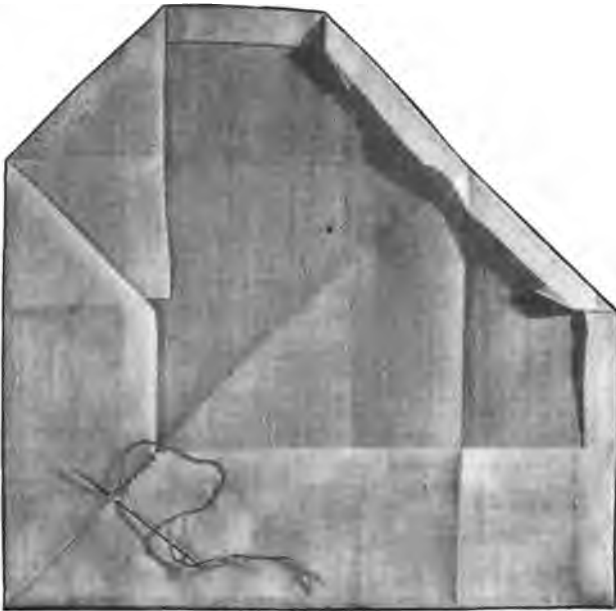

**MITERED CORNERS**  
Method of Folding and Cutting.

**Rolled Hem**

Rolled hem and whipped gathers are made with the wrong side of the material next the worker. Make a tiny roll of the edge towards the worker, using the

**ROLLED HEM AND WHIPPED GATHERS**

*a*—Rolled Hem Gathered; *b*—Whipped Roll; *c*—Double Whipped;  
*d*—Roll Hemmed; *e*—Gathers Sewed to Band.

left thumb and index finger, rolling an inch at a time (and no more) before hemming. Make fine, even stitches in the roll and goods. Keep the hem perfectly round, firm and not too large. This hem is adapted

only to fine material and the edge across the warp is the more easily rolled.

To gather, whip the rolled hem without hemming, making overcasting stitches towards you, even and not too fine. Use coarser thread than for hemming. This gathering thread is used to hold down the edge as well as for drawing up the gathers and is not to be taken out, as is the ordinary gathering thread. It should *not* catch in the roll. Have the thread the length of the plain space to which it is to be sewed and regulate the gathers as you do the gathering. After the edge is rolled, whipped and gathered, it is sewed to the garment by the little scallops or raised parts made by the whipping. This is used only for making ruffles or gathering on very fine hand work.

**Whipped  
Gathers**

The French hem is used for table linen. Fold as in an ordinary hem, then fold the hem back on the right side and overhand the edge formed, taking fine stitches. Press the hem flat from the right side.

**French  
Hem**

Flannel hems should *not* be twice folded, for there will be a ridge instead of a flat surface after the garment has been laundered, owing to the felting properties of the wool. Hems on flannel should not be stitched by hand or machine, but cat stitched on the wrong side and finished on the right side with any ornamental stitch.

**Flannel  
Hems**

Hems in infants' clothing may be turned on the right side and made ornamental by feather stitching.

No selvage should ever be used on a hem. The selvage is more closely woven and will draw or pucker in laundering.

**TUCKS**

Tucks are folds made on thin material for ornament, to shorten or to provide for lengthening a garment. If done by hand, a card measure is preferable to a tape measure for marking the space and width of the tucks. The folds should be creased to a thread, basted and sewed with a running stitch showing but little on the face, or stitched on the machine. Fine thread should be used.

**SEAMS**

A seam is the line of sewing that joins material; it may be plain or ornamental. The most important are the overhand, felled, French, slot, lapped, flannel, and beaded.

The overhand seam is described under the overhand stitch.

**Felled  
Seam**

A fell is a seam hemmed down to the goods to protect the raw edge. It is usually made in night dresses, drawers, corset covers, etc. Baste with the piece farthest from the worker extended one-eighth of an inch beyond the other and sewed *with the grain* of the goods, beginning at the widest part of any bias. Press the seam with the nail on the right side, turn the wide edge down flat to cover the raw edge and line of sewing, and hem flat either by hand or machine. Care should be taken to keep the seam flat on the right as well as on the wrong side. If the felling is done with the machine hemmer, the wide edge must be on the opposite side. The seam may be basted with

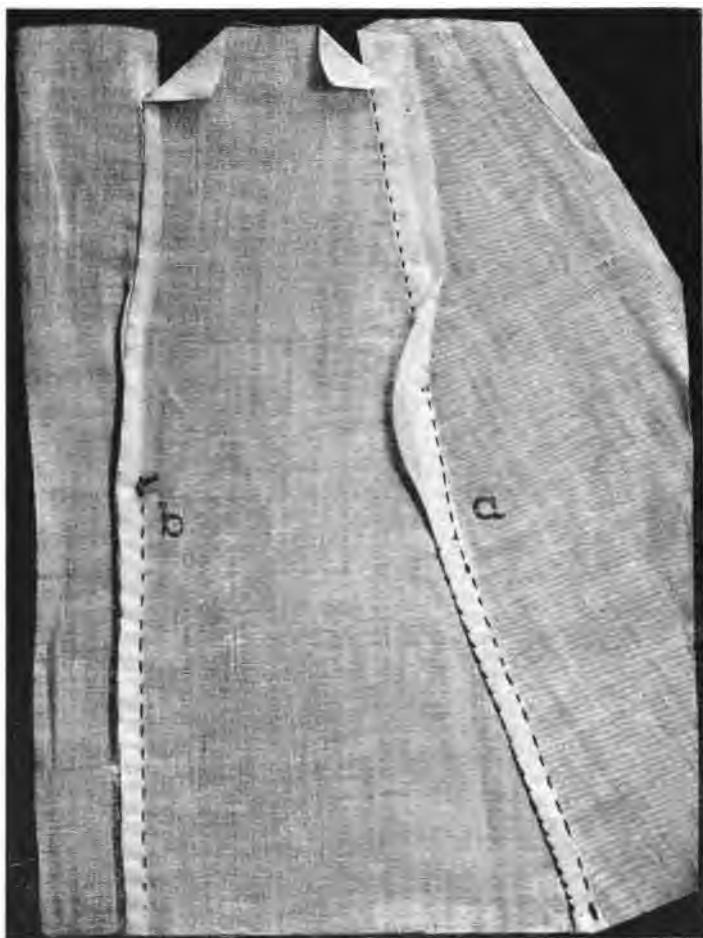

**SEAMS**

*a*—Full; *b*—French Seam.

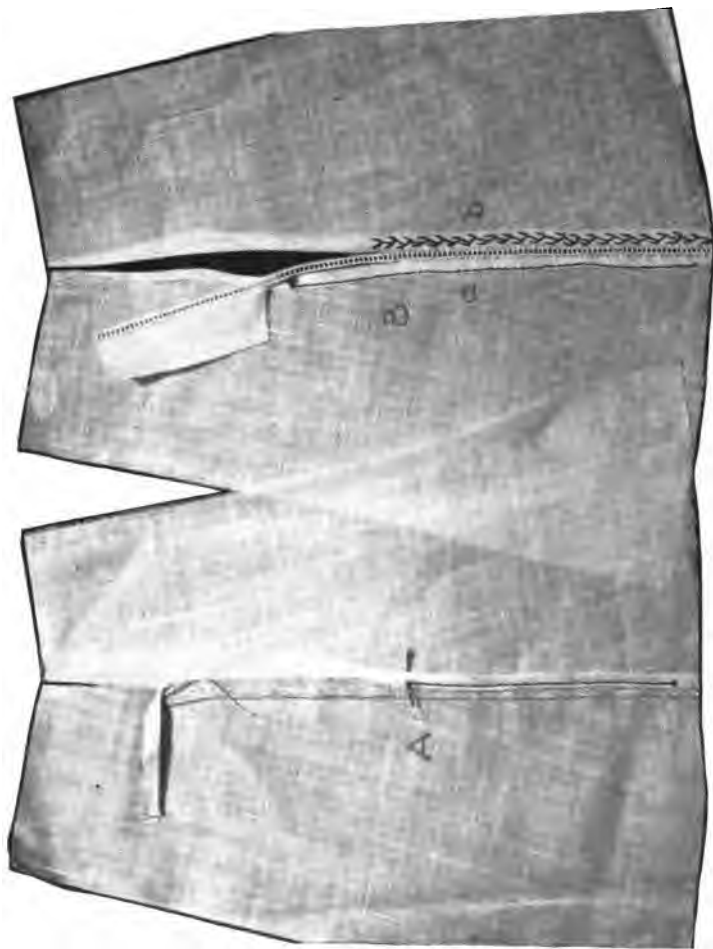

**BEADED AND TAPED SEAMS**

**4**—Tape basted on one edge, and the other edge turned and stitched; **B**—Beading whipped to the folded edges;  
**a**—Stitched hem; **b**—Hem finished with feather stitching.

both edges even if preferred, cutting off one edge after stitching.

A French seam is sewed twice—first on the right side as near the raw edge as possible. Cut off all frayed edges, turn the material by folding *on the seam* or line of sewing, so the seam is folded inside and the second sewing is on the wrong side below the raw edges. This is not a good seam for underwear worn next the body, as it leaves a ridge on the wrong side, but it is useful for skirts of thin material, etc. It is more easily made than a fell.

**French  
Seam**

Beaded seams used for fine white work have a line of beading overhanded between gores, hems, or gathers. The hem along the seam should be folded on the right side, leaving a perfectly flat surface to iron on the wrong side, and finished with an ornamental stitch covering the hem.

**Beaded  
Seam**

The slot seam, used in cloth dresses and jackets, requires exact basting with silk or very fine thread with small, even stitches. If a coarse thread is used, the material will be badly marked. After basting, press the seam open as if it had been stitched, and baste the strap or under strip of the dress material (which has been cut perfectly straight and even) over the wrong side of the seam, having the center of the seam on the center of the strap. Stitch any width desired beyond the center through the three thicknesses. This will hold the seam in position. Now remove the bastings from the seam and the slot effect is complete. If

**Slot  
Seams**

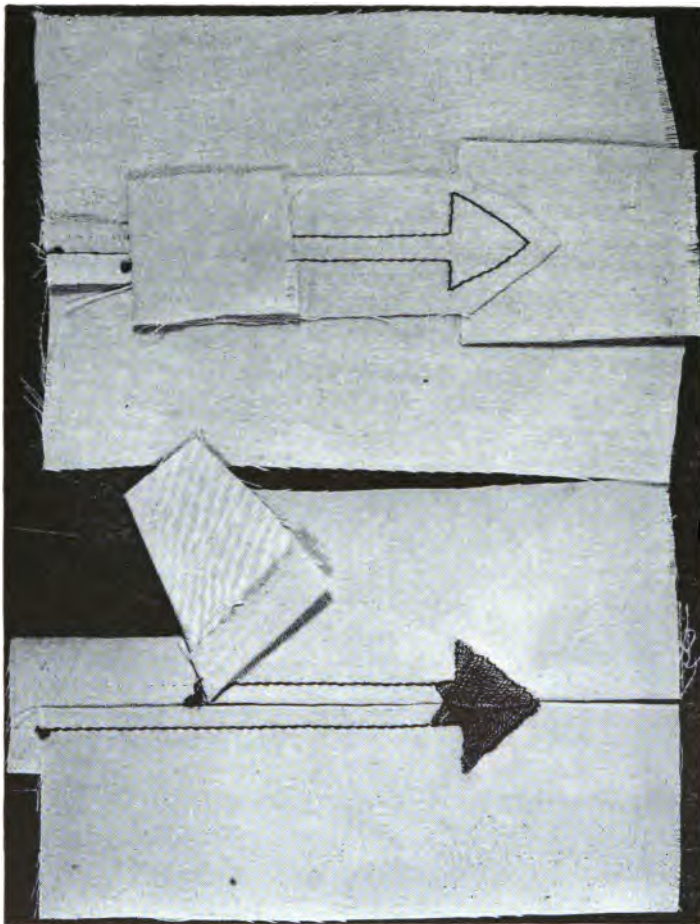

**SLOT SEAM FINISHED WITH ARROW HEAD**



desired, there may be a double row of stitching, an extra row on the edge of the fold or plait. These seams may be finished at the bottom with arrow heads or stitched designs. The lines of machine stitching



**FLANNEL SEAMS AND HEMS**  
Finished with various Ornamental Stitches.

should not end without some ornament to *appear* to hold the plait.

In the lapped seam the edges are folded each within the other or one over the other so that both sides are alike. If made of heavy material, the raw edges are

**Lapped  
Seam**

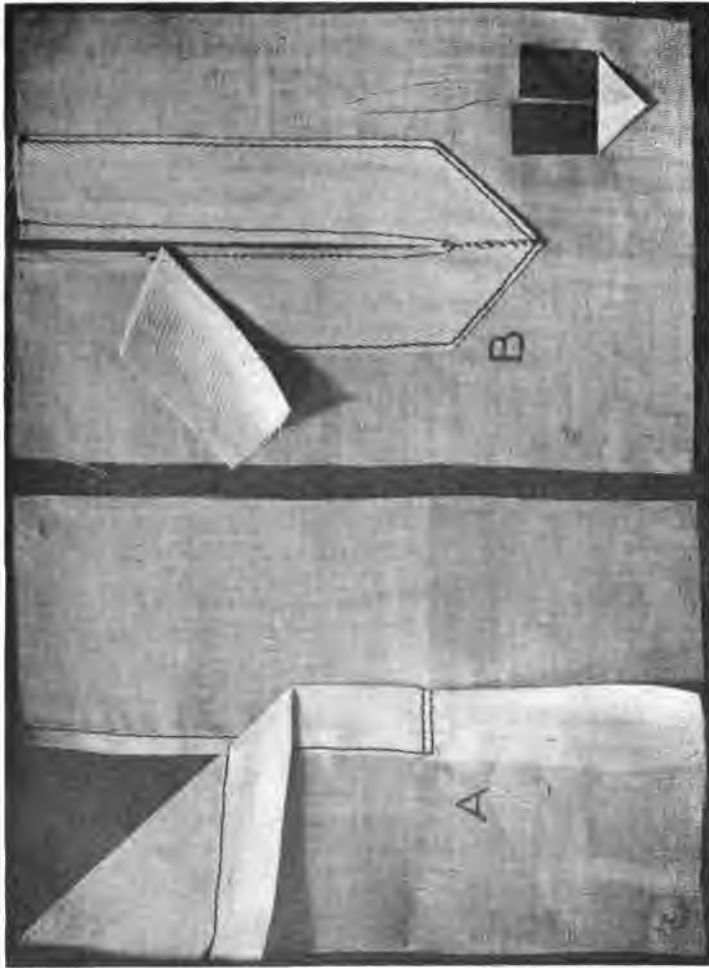

#### PLACKETS

*A*—Made by folding a wide hem over a narrow one; *B*—Tape faced sewing for the purpose of a gusset.  
Method of folding the tape shown.

left unturned; in muslin or linen the edges are in-turned, lapped, basted and the hem stitched on both edges or hemmed down on both sides by hand.

Flannel seams should be stitched, opened and pressed *flat*, either on the right or wrong side of the garment. If on the right side, taffeta ribbon should be basted over the seam, so that the raw edges of flannel will not show, and cat stitched or buttonhole stitched on both sides of the ribbon, or any fancy stitch—not too long—may be used. This is the Dorothy seam. For the seam on the wrong side, the edges should be cat stitched with fine thread. Any ornamental stitch may be used on the right side of the seam. Always press flannel seams and hems before finishing. Flannel should never be hem stitched.

**Flannel  
Seams**

#### PLACKETS

A placket is an opening in a garment allowing it to be put on. The simplest placket is made by cutting a slit and folding a wide hem over a narrow one turned on the face of the goods; this makes a pleat below the vent. There should be a double line of stitching across the bottom of the hem to strengthen the placket.

The tape faced placket is stronger and may be used in children's drawers, etc., in place of a gusset to strengthen the end of the opening. A single piece of tape folded back as for a loop is stitched along all edges, making an opening without a lap. This offers as much resistance as a gusset and is more quickly done.

**Tape Faced  
Placket**

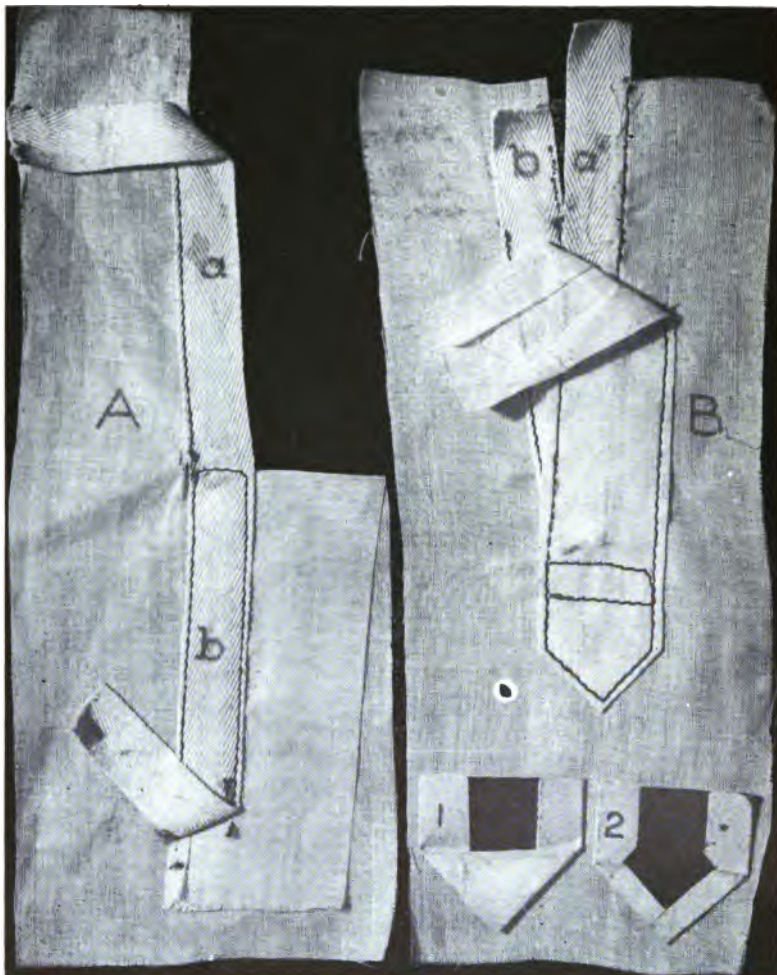

#### FACED PLACKET

*A*—Wrong side, opened, showing tape; *B*—Right side showing on-set piece; *aa* and *bb* the same ends of the tape; 1-2 method of folding and cutting end of on-set piece.

In a third kind of placket, the opening is faced with a continuous piece of tape on both sides and finished with a piece of material on the outside. See illustration. This makes a strong and simple placket. When

**Faced  
Placket**



**SKIRT PLACKET WITH LAP**

a tape cannot be used, a hem or facing may be made on the under side of the opening and a facing on the upper side, over which the on-set piece is stitched. The on-set piece and facing may be cut from one piece, but the fitting is more troublesome. In figured goods, the piece set on should match the pattern exactly.

A simple placket for underwear is made from a single strip of the goods put on like an extension hem. On drawers it may be turned in at the button-hole end, but not stitched down except at the band.

The placket of a skirt should have an underlap extending well below the opening.

#### SEWING ON BANDS

##### Gathering

Divide the top of unhemmed edge of the garment in halves and mark with a cross stitch, notch or pin. Gather from the placket to the middle of the front gore, if a skirt, apron, or dress. Take a new thread and gather the remainder. Put in a second gathering thread one-eighth to one-fourth of an inch below the first. Two gathering threads are better than one and they should be longer than the length of space to be gathered. Stroke or lay the gathers above and below the threads. Divide the band and pin the middle to the center of the garment, placing the right side of the band on the wrong side of the garment. Pin in the middle and at each end, secure the gathering threads by winding around the pin, adjust the gathers, and baste between the gathering threads. Stitch just below the line of basting. Fold the band over on the right side, press, baste over the line of stitching, press again, then stitch on the right side after having turned in both ends and over-sewed. Turn the *top* of the band over on the right side one-eighth or one-fourth of an inch and stitch securely. This upper fold keeps



**FINISHES**

**a**—Bias Facing; **b**—Band on Gathers; **c**—Corded edge.

the edge from wearing and stretching and is a stay for children's skirts and drawers where button holes are used and serves as a finish for the top of the band.

For flannel, pleating or gathers may be used to put fullness into a band. Two rows of gathering threads



**DRAW TAPE FINISH FOR UNDER SKIRT**

should be used and the stitches should not be too fine. The band should be made of cotton or at least lined with it to avoid clumsiness and prevent shrinking. Ruffles are set in hems, etc., in the same manner.

In finishing the top of an underskirt, many like to dispense with the placket and fitted band. This may be done by using drawing tapes at the back. The upper edge is faced with a piece of material which should be bias in front to accommodate it to the curve, but may be straight across the back. Work a button hole

**Drawing  
Tapes**



at each side of the back, insert a tape through one button hole and draw it over an inch beyond the opposite one and fasten securely by two lines of stitching across the tape. A second tape is put through the other button hole and fastened in the same way. By pulling the tape on each side the fullness may be adjusted.

All facings around curves, such as arm holes and neck, should be a true bias which is cut by holding the warp threads diagonally across the woof threads. These strips for facings, pipings, ruffles, etc., should be cut exactly even in width. All bands, ruffles, etc., of serge, twilled, or diagonal materials should be cut *across* the twill and not with it, in order to have the ruffle hang well.

**Bias  
Facings**

#### FASTENINGS

The standard fastenings are buttons and button holes, hooks and eyes or hand made loops, lacings through rings and eyelet holes, loops over buttons, and fancy frogs, clasps, studs, ball and socket, "notta-hooks," etc.

Button holes should be carefully measured and marked before cutting. They should be a little longer than the diameter of the button for flat buttons and one and one-quarter the diameter for round buttons. Having decided upon the distance apart they are to be placed, cut a marker from a piece of cardboard and measure off the space, marking with pins, French chalk, pencil, or thread. The distance from the edge (one-fourth inch), as well as the length of the button

**Making  
Button  
Holes**

hole may also be marked with the card. The scissors should be sharp, the hand must be steady, and the cut should be made with one firm slash, not with two or three jerks. Great care must be taken that each button hole is of the same length. The goods should be cut to a thread, for it is impossible to make a neat buttonhole if it is improperly cut. In cutting a round end buttonhole for thick goods, a punch may be used for the end, after which the remainder of the buttonhole is cut directly on a line with the center of the circle.

The same marker may be used to mark the position for the buttons. All markings for buttons and buttonholes, or for hooks and eyes, should be made at one time.

**Overcasting  
Buttonholes**

After cutting, the button holes are overcast. This should always be done directly after cutting, especially if the goods ravel easily, otherwise it will be impossible to work a neat buttonhole. Overcasting should be done with very fine thread (No. 150 for white goods), split silk for wool and silk. Three overcast stitches on each side are sufficient for an ordinary size buttonhole.

A very good plan to follow in cutting a buttonhole in heavy material or material that frays easily is to chalk the position and length of the buttonhole, then stitch a row of machine stitching each side of this mark, the two rows being a little more than one-eighth of an inch apart. This holds all the thicknesses to-

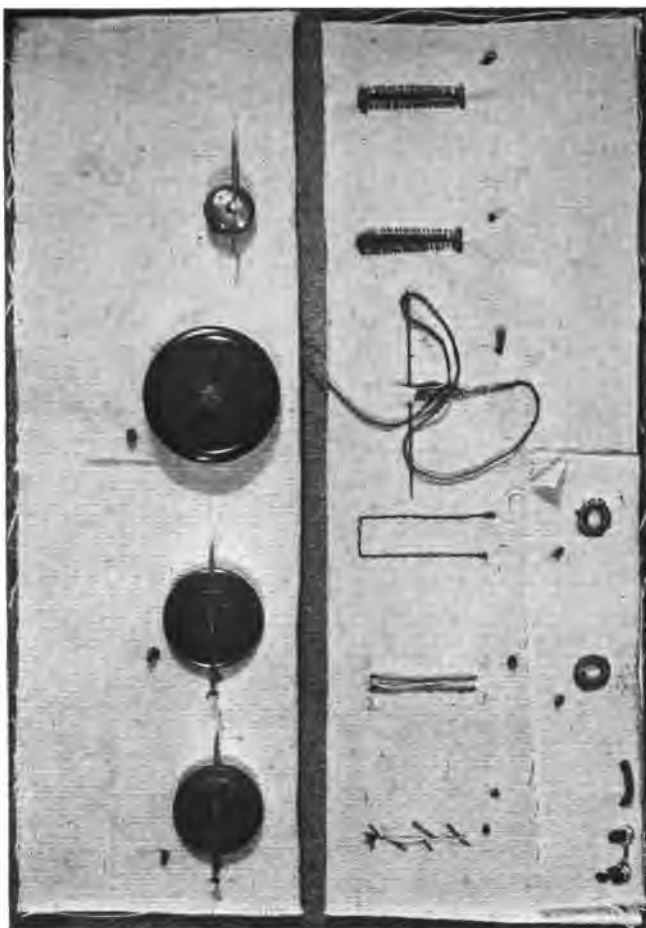

**BUTTONS, BUTTON HOLES, EYELETS, LOOPS**

gether and the buttonhole may then be cut easily. It also serves as a guide in working the buttonhole stitches.

The buttonholing is begun at the inner side of the slit. Always place the knot on the outside of the garment a short distance to the right of the buttonhole, leaving a long stitch underneath which can be cut off when the buttonhole is finished. A buttonhole should be completed with one thread if possible as it is difficult to mend the thread securely and neatly. Letter D for twist is usually employed.

**Making  
Buttonholes**

Insert the needle in the edge of the material and when half way through, take the two threads at the eye of the needle, bringing them towards you at the right and under the point of the needle, and draw the thread from you, making the purl or loop stitch directly on the edge of the buttonhole. The stitches should be about the width of the needle apart to allow for the purl. Be careful to complete each stitch with a uniform movement so that the line will be perfectly straight and not wavy. The stitches are placed more closely together in the rounded end of the buttonhole where the chief wear comes.

**Staying**

Many workers, particularly tailors, always "stay" or "bar" around a buttonhole before working. This may be done with several threads of twist or with a cord so that the worked edge of the buttonhole will be firm and distinct. Tailors usually use a cord as this makes the edges heavier. It is always well to stay button-

holes in heavy material as it strengthens them very much and improves their appearance.

When the buttonhole has been worked all around, the end is completed with a bar tack made by taking two or three stitches across the end of the buttonhole, drawing the edges closer together. This bar is covered with buttonhole stitches worked close together. The thread is fastened securely on the wrong side.

**Bar Tack**

After very large buttonholes are finished, their straight edges should be closely basted together by an over and over stitch and then pressed under a damp cloth. Before they are dry, a bodkin or stiletto should be pushed vigorously up through each eyelet until that opening becomes perfectly round and the stitches on its edges are regular and distinct. When the basting is removed, the buttonhole will be symmetrical in appearance.

**Large  
Buttonholes**

Buttonholes which are to bear a strain are cut in the direction of the pull, but sometimes they are cut in the opposite direction, as for a shirt waist. Such a buttonhole may be completed with a bar tack on each end.

Ordinary buttons should never be sewed down tightly, but the thread should be loose so that it may be wound around at the end, thus protecting the holding threads from wear. The shank prevents the buttonhole from being crowded out of shape. Loose sewing can most easily be done by placing a pin or needle across the top of the button and sewing over

**Sewing  
on Buttons**

it. If a button is much concaved, the pin may be placed underneath. The pin is removed before winding.

In sewing on a four-hole button, the stitches should be made symmetrically, either parallel or crossed, but not both. If parallel or in a two-holed button the stitches should run in the line of the buttonhole. The thread should always be fastened securely at the beginning and at the end of the work. Place the knot upon the outside of the garment where it may be cut off when the button is sewed securely. The knot is sometimes placed under the button.

**Cloak  
Buttons**

In sewing buttons on a cloak or coat an extra strip of canvas or silesia over the canvas interlining should be placed the entire length of the buttoning for strength. This should be applied before the work on the garment is too far advanced and if cut sufficiently wide, will allow of any slight alteration. The sewing should go through the canvas facing and stay, but not through the under side or facing of the material.

In sewing buttons on bodices a tape should be sewed over the front basting for a stay. If sufficient material has not been allowed for a lap, this should be added, as a lap is necessary under the opening of such buttonholes.

Buttons may be sewed through lining having a small button on the wrong side. This method prevents the cloth from tearing and makes an ornamental finish as well as a substantial one.

Buttons which are supplied with wire shanks should be sewed down firmly as the shank already provided permits the buttons to set up well from the material. They should be placed in such a position that the wire shank will run parallel with the buttonhole and not cross it.

The position for hooks and eyes should be marked before sewing on. The simplest, though least desirable, method of sewing on these fastenings is to place the eye at the edge of the seam or facing and the hook sufficiently far back from the opposite side to give a lap. A much preferable method is to baste a bias strip of crinoline along the positions to be occupied by the hooks and eyes; this gives strength to the finish. Sufficient material should be allowed for folding over the shanks after the hooks and eyes have been sewed on, or they may be covered with silk ribbon, slipping the edge under the beak of each hook and then catstitched in position.

The hooks and eyes are sewed securely through the crinoline and one thickness, but the stitches should not show on the outside. Over and over stitches are taken through the small rings in the line of the full and again on each bar of the eye and on the shank of the hook so that they may be held in position securely. In many cases, it is advisable to have an underlap of the material. This should be slip-stitched in position on the garment after the eyes have been sewed in place.

**Hooks  
and  
Eyes**

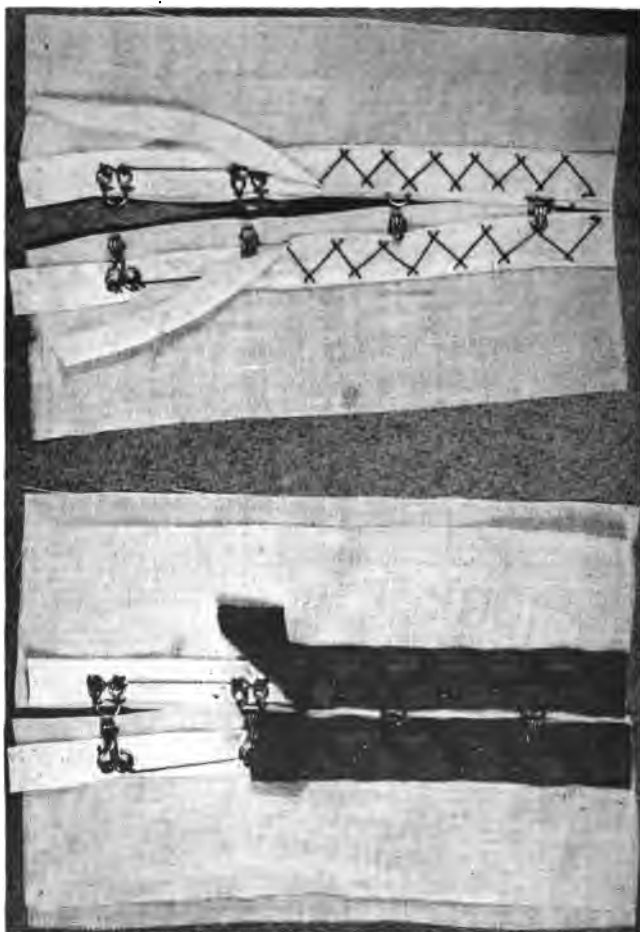

**HOOKS AND EYES**

Sewed on tape, Shanks covered with taffeta tape and with fold of the goods.



Eyelet holes are made with a stiletto which forces the threads aside, but does not cut them. The edge is finished with over and over stitches placed closely together, or with a buttonhole stitch making the purl on the outer edge of the stitches. Loops are made by buttonholing very closely over several foundation threads, making the purl on the outside edge. The needle may be run under the loop eye first if preferred.

**Eyelets****PATCHING**

With the underset patch have the part to be patched pressed smooth, baste the patch on the wrong side of the garment before cutting out the worn place. (If the garment or article to be mended is worn or faded and shrunken by laundering, boil the piece in soap, soda and water to fade the patch, if of cotton or linen.) After basting, cut away all the worn cloth, making a square or oblong hole. Cut to a thread. Cut each corner, diagonally, one-eighth or one-quarter of an inch, turn all four edges of the garment towards the wrong side. Begin at the center of one side and hem all around the square, taking slanting even stitches, not too close together. Remove the basting, trim the edges of the patch, press the patch on the wrong side and catch stitch to the garment. This shows less on the right side and does not make a hard line as if the patch were turned back on the edge. If the cloth has a pattern or stripe, match it perfectly, having the warp threads of both running the same way. Cut both hole and patch square. An oval or round patch is un-

**Underset  
Patch**



**UNDERSET PATCH, RIGHT SIDE, EDGE TURNED AND  
HEMMED TO PATCH**

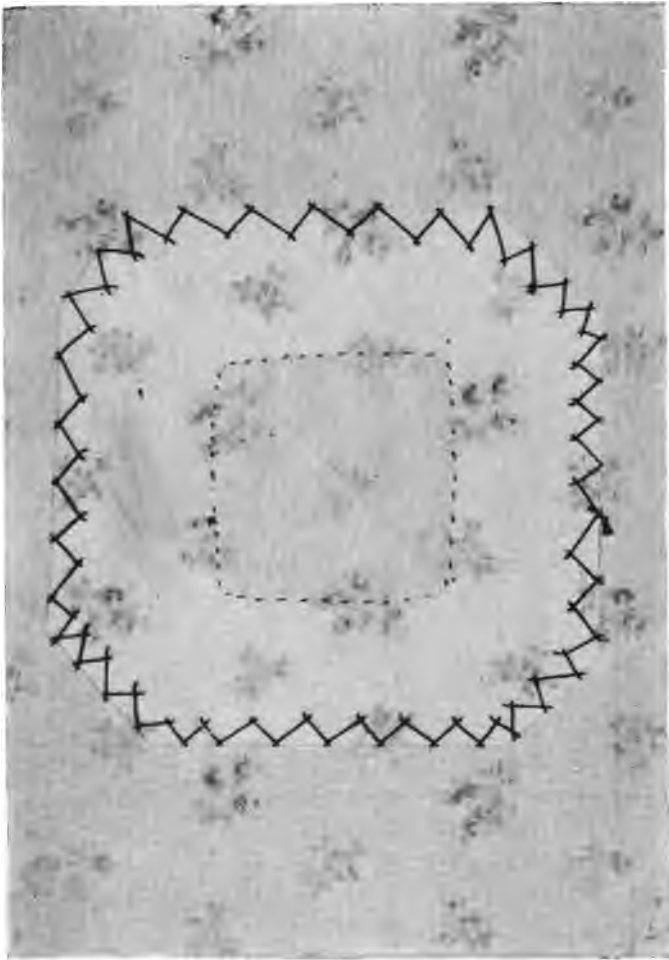

**WRONG SIDE OF PATCH, CAT STITCHED**



WRONG SIDE OF PATCH IN TABLE CLOTH—RAW EDGE  
OVERCAST

workmanlike and does not wear well. Keep the corners square and hem down well. The object of pressing is to keep both garment and patch flat and even. Flannel patches should be cat-stitched on the right side. No flannel edges should ever be inturned.

**Onset  
Patch**

The onset patch is used on lined garments and linings. The patch should be rectangular and larger than

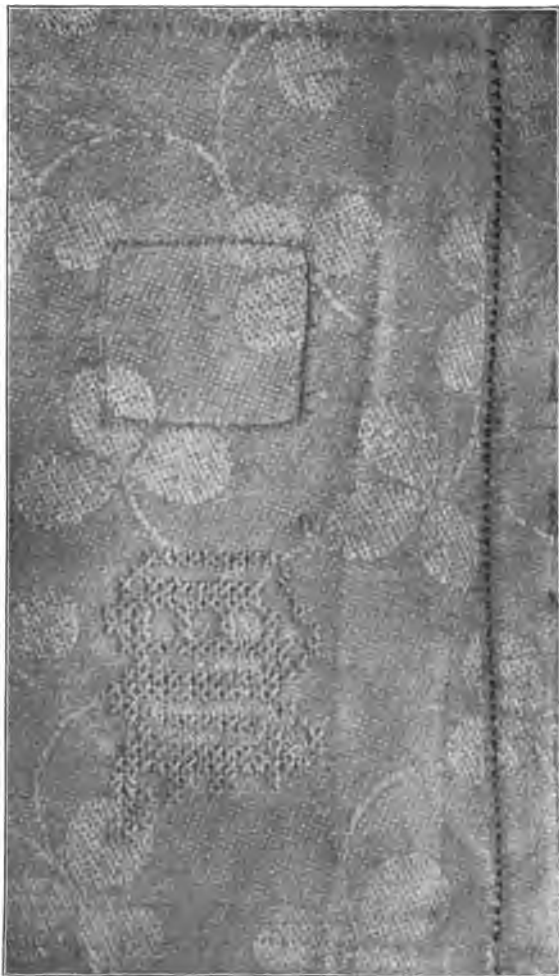

**LINEN PATCH; CROSS STITCH INITIAL**

the worn place. Fold the four edges on the wrong side of the patch, place the patch with its wrong side on the right side of the garment directly over the center of the hole. This will bring the folded edges of the

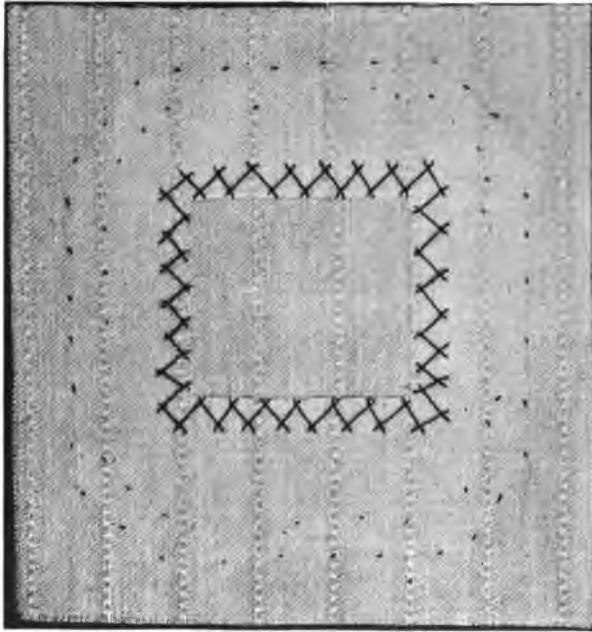

**RIGHT SIDE OF FLANNEL PATCH**

Edge cat stitched but not turned, back cat stitched in the same way.

patch between the two pieces of cloth and both right sides towards the worker. Do not baste, but pin carefully. After the garment has been folded back until there are two folded edges side by side, overhand the

seam with even slanting stitches. See that the corners are well sewed, that warp and woof threads run in the same direction, that pattern and stripes match.

The worn part of the garment under the patch is cut away, leaving one-fourth of an inch on the three sides. Cut the corners diagonally and turn back the edge quarter of an inch, overcast and press. If this patch is sewed on a lining, the worn part is not cut away. If this patch is used to repair skirts near the band, only three sides are oversewed, the upper edge should be gathered into the band. A large patch is less conspicuous than a small one.

An onset patch may be used for the seats of trousers by shaping the patch like the pieces on the seats of bicycle trousers and stitching on the machine. Heavy cloth will need no inturned edges. The same precautions are necessary regarding warp and woof, pattern, etc.

**Patch for  
Trousers**

#### **DARNING**

Darning is usually done with a running stitch, with or without a piece of net or cloth under-set. Thread for darning should be as near as possible the size of the threads in the garment. Whenever it can be done, a warp thread of the garment should be used. No sewing silk is fine enough to use without separating the thread and using one of the strands. Never use the thread as it is, as it is too hard twisted. Cotton and linen thread of the finest quality, untwisted, should be used for darning stockings and underwear. Linen may

**Thread for  
Darning**

be darned with linen or mercerized cotton. Cotton is preferable.

A long slender needle with a large eye should be used. Darning should never be commenced with a knot, nor finished with a back stitch.

**Bias  
Darn**

A bias or diagonal cut and a three-cornered tear are the most difficult to repair. If the place is badly pulled and frayed, a piece of the same material should be basted on the wrong side of the material and darned in even stitches. Always darning *parallel* with the warp threads and the woof threads. In the diagonal tear, as the threads are cut diagonally, to prevent drawing apart, the darning threads must cross each other.

The stitches around any darn should not end in a stiff even line; this makes a hard edge which does not wear and is unsightly, and uncomfortable if on underwear.

**Darning  
a Three  
Cornered  
Tear**

The three-cornered tear may be darned in two ways. Begin by darning diagonally through the center, darning back and forth towards the end of the tear until one-half has been finished; then begin at the center and work in the opposite direction. At the corner, the stitches should form the shape of a fan. The other method, which is the stronger, is done by darning a square in the angle, first with the warp threads, then with the woof threads and finishing each end across the tear.

Stocking darning may be done on the right side. Begin by picking up the stitches and drawing the



edges together. This should always be done in any kind of stocking darning, but not so close as to make a wrinkle.

In knees and heels of stockings, or knitted under-

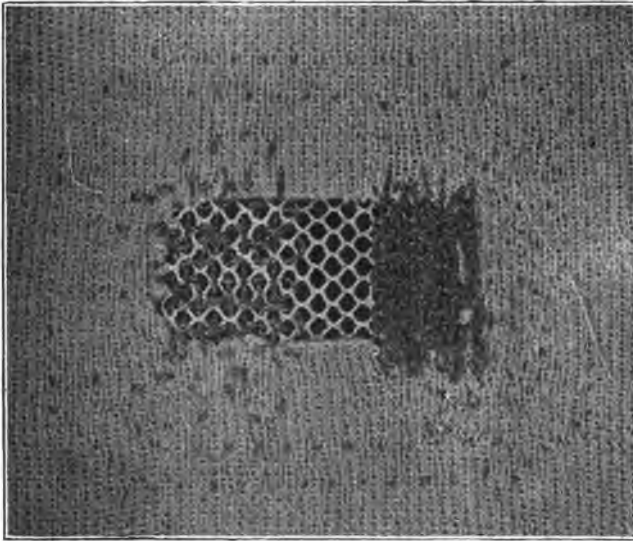

**STOCKINET DARNING OVER NET**  
Interlaced Stitches and Chain Stitches.

wear, a piece of net large enough to extend beyond the thin part should be basted carefully; then darn down the outer edges of the net and finally the hole or thin place. This makes a strong, neat piece of mending. If the hole is large, the net may be covered with the

chain stitch, thus imitating the knitting stitch. This should be done on the right side of the garment.

If the hole is to be filled in with the interlaced stitches, draw the edges together, darn beyond the thin places lengthwise of the knitted garment, making each line of stitches longer until the center of the hole is reached, then decrease in the same manner, making a diamond in shape. Darn across the hole in the same way, taking up every alternate stitch as in weaving. Leave a tiny loop at the end of each row of darning, so that the threads will not draw.

**Machine  
Darning**

Darning, satisfactory for some purposes, may be done quickly on a double thread sewing machine. It is best done in an embroidery ring, first drawing the edges together. Loosen the tension on the presser foot, use fine thread with light tension. Sew back and forth, first along the warp threads and then at right angles along the woof threads. The machine will be sewing backwards part of the time, but if the pressure is light, there will be no difficulty. For large holes, paper may be placed underneath.

**MITERING EMBROIDERY OR LACE**

The mitering of lace or embroidery is often necessary in making collars and in finishing corners. Before applying, plan carefully and select a scallop or portion of the embroidery which will produce the best effects when finished. This can be accomplished by folding the embroidery over at various portions of the

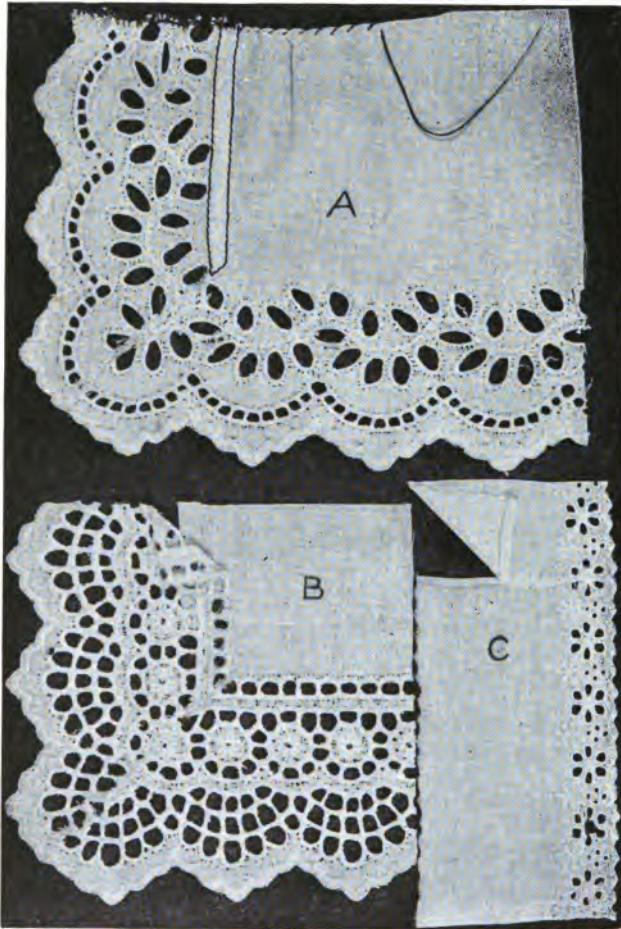

**MITERING AND JOINING EMBROIDERY**

**A**—Finished with a stitched seam ; **B**—Edge hemmed down and cloth cut away underneath ; **C**—Joined with lapped seam.

pattern until a suitable point is found. Fold over at right angles and mark along the line to be mitered. The triangle may now be cut, but an extra width must always be allowed for the seam, as there is frequently a slight unevenness and one side may have to be held a little full or stretched to make a perfect match. The mitered seam is over-sewed.

After the corner is properly made, cut away the cloth of the embroidery, allowing only enough for an inturned seam on the edge. This seam may be stitched on the machine on both edges, or oversewed to the goods, or the embroidery may be securely sewed on the plain part, after which the underlying cloth may be cut away. This will make an almost perfect corner.

Lace may be matched and mitered in a similar way.

#### MATCHING AND JOINING LACE

In joining lace, avoid a seam if possible. Select portions of the design that will match, placing one pattern of the same design over the other. Cut away a portion of the thick part of the pattern underneath and hem the edges and inner part of the design down with fine thread.

Smyrna or Torchon lace is more difficult to hem or join when very open or very fine. A small, felled seam is better than lapping and trying to match the pattern.

Embroidery can be matched in the same way. Never let two heavy designs lap over each other. The one



**INSERTION WITH MITRED CORNER, TAPED AND FACED;  
EMBROIDERY ROLLED WHIPPED AND GATHERED**

on the wrong side should be cut out and the edge sewed securely to the upper part of the design.

The plain material above the embroidery can be joined by a lapped seam, turning first the right side and then the wrong side and hemming on both sides of the seam.

## MACHINE SEWING

The sewing machine has taken away much of the drudgery of home sewing, but its use does not lessen the need of skill in hand work. No machine can finish ends of belts, collars, sew on trimming, fastenings, and like work and the finish has much to do with the general appearance of a garment.

### Types of Machines

All the prominent makes of sewing machines were invented in the decade following Howe's patent in 1846. The two chief types of machines are the lock stitch, using double thread, and the chain or loop stitch, using a single thread. Whatever the make of machine it should be run in accordance with the rules accompanying it. The worker should familiarize herself with the directions for setting and threading the needle, winding the bobbin, regulating the tension and the stitch and all other technicalities of the particular machine she has to operate. Agencies of the various machines usually have skilled workers to give instruction to beginners. While it is not always an economy of time to use the attachments for hemming, tucking, etc., unless much work is to be done, it is worth while to know how to use them if desired. As much or more skill is required for neat machine work as for hand sewing. Results will not be satisfactory without careful basting.

### Care of the Machine

The machine should be kept well oiled, free from dust and gum and it should be run evenly. In case it becomes "gummed" a drop of kerosene on the parts

that have been oiled will cut the gum. Remove the shuttle and run the machine rapidly for a moment, then wipe off all the kerosene and oil the machine carefully with good machine oil—only the best should be used. A machine should always be wiped thoroughly before any work is placed upon it.

As in hand sewing, needles and thread should be selected with care. A blunt or bent needle should never be used, it should have a fine sharp point and the eye should be sufficiently large to carry the thread easily. The needle and thread should be suitable for the material to be sewed. Glazed thread should never be used in a machine. The best quality of thread and silk should be purchased but only enough for immediate use, as it loses strength with age, chiefly because of the action of the dyes and chemicals. Even white thread may become "tender" from the chemicals used in bleaching it. Sewing silk and cotton should be kept in a closed box to exclude the light and air.

**Needles  
and  
Thread**

For sewing cotton or linen the best cotton thread should be used. Woolen, silk, and velvet should be stitched with the best machine silk. The thread should match the material in color. Cotton thread fades or loses its brightness when exposed to the light, therefore for stitching that will show it is always better to use silk. The thread on the bobbin should be wound evenly and carefully to insure an even stitch and the tension of both threads should be equal, otherwise the stitch will not be perfect. As a lock stitch machine

requires two threads while in hand sewing only one is used, the two need not be as coarse as the single thread. For ordinary home sewing, underwear, thin gowns and the like, No. 70 to No. 100 will be found satisfactory. Finer thread may be used when the materials demand it, but no coarser than No. 50 should be used in the machine and this only with the coarsest material.

**Fastening  
Threads**

Much time may be saved in fastening the threads at the ends of tucks, hems on sheets, towels, etc., by careful manipulation of the machine. For example, on sheets begin to stitch along the hem at the selvage, or if the end of the hem is over-sewed, begin an inch from the edge and stitch the hem towards the selvage, then lift the presser-foot so as to turn the work, and retrace the bit of stitching, continuing across the whole hem. When the end is reached, release the presser-foot, turn the work, and stitch back for an inch or more in the same line, as was done at the beginning of the hem. By this method the threads are fastened much more easily and quickly than by drawing them through on to the wrong side and tying or sewing them by hand and, of course, it is more satisfactory than the "shop" way of cutting them off short. Tucks or seams may be fastened in the same way. If fine thread is used the double stitching at the ends is hardly noticeable.

**Bias Side  
Next Feed**

When stitching a seam having one bias and one straight side, let the bias side come next to the feed,



that is, on the underside. This is especially important in thin materials. If the material is very sheer, strips of soft paper—newspaper will answer for ordinary purposes—should be sewed in the seam. This will insure a seam free from puckers and when finished the paper can be pulled away easily.

In sewing gathers on a band they should also come next the “feed,” as it takes up the side next to it a little faster than the upper side. When the bias, or cross-way side of the seam, or gathers are next to the “feed” the material runs along smoothly, but if the straight side is towards it there is apt to be a pucker.

**Stitching  
Gathers**

Stitching can be done more easily on the right of the presser foot with the bulk of the material lying to the left. The tendency of the “feed” or teeth is to crowd the work off the edge as well as forward and the stitching may be guided better on the right side.

All straight seams should be stretched to the full extent of their straight edge in stitching, as the work passes under the presser foot .

When a large amount of machine sewing is to be done—such as household linen, sheets, pillow cases and underwear—it is a good plan to do all the basting and hand work first and keep the machine stitching for a rainy or a damp day, as the thread is then less apt to break. A current of air or a breeze from an open window on a dry day will often cause the thread to snap. For the same reason the machine should never stand near the fire or radiator.

## TEXTILES AND CLOTHING

### PART II

---

**Read Carefully.** This test consists of two parts,—answers to the questions and the making of models. Both should be sent to the School for inspection and correction. All models should be made about 4 by 6 inches so that they may be put into the envelope provided without being folded. Two series of models are given; either or both may be made.

---

1. What instruction have you ever had in sewing?  
(b) Has the subject any educational value?
2. What are the common basting stitches, and for what are they used?
3. Can you make the running stitch properly? How is it done?
4. For what purpose may the cat stitch be used?
5. Hems and Seams: Describe the different kinds for thick and thin materials, including those for flannel and state when they should be used.
6. Describe three kinds of plackets.
7. How are gathers made, and how sewed into a band?
8. What can you say of fastenings?
9. With what sewing machine are you most familiar, and what are its peculiarities?
10. What stitches or methods described in this lesson are new to you?

**Note:** After completing the answers, sign your full name.

## TEXTILES AND CLOTHING

### MODELS, FIRST SERIES

- I. **STITCHES.** On a piece of cotton about 4 by 6 inches, make with colored thread (1) a line of even basting stitches, (2) uneven basting stitches, (3) tacking, (4) running, (5) back stitch, (6) running and back, (7) half back. With embroidery silk make a row each of (1) cat stitch, (2) single feather, (3) double feather, (4) chain, (5) rows of French knots with border of outline stitch. Make your initial in one corner, using any stitch preferred. Overcast one long edge of the model, double overcast the opposite side, finish one end with plain loop or blanket stitch, and the other end with some fancy loop stitch. Fasten all threads as described in the text.
- II. **SEAMS AND HEMS.** (a) Join two pieces of fine cotton with a French seam at the long edge, about 2 by  $5\frac{1}{2}$  inches, with warp running lengthwise. (b) Cut a piece of muslin on a true bias and attach the bias edge to *a* with a felled seam. (c) Trim the model and hem all sides so that the finished model may measure 4 by 6 inches.
- III. **DARNING AND PATCHING.** (a) In gingham or figures cotton, make an underset patch of a square hole, matching the goods. (b) Darn a three-cornered tear.
- IV. **FASTENINGS.** The proper distance from the edge of folded goods make (a) button hole, one end rounded and the other finished with a bar tack. (b) Under it make a partly fin-

## TEXTILES AND CLOTHING

ished, *barred* buttonhole. (c) Below this make an eyelet hole, (d) below the eyelet hole a loop, and sew on an eye.

On a second piece of folded goods opposite the first buttonhole, (a) sew a four-hole button, corresponding in size to the buttonhole. (b) Opposite the second buttonhole sew on a two-hole button; (c) below, on other side of the goods, sew on two hooks for the loop and eye. Make the two parts of the model so that the corresponding fastenings will join.

- V. APRON. Using fine muslin, make a doll's apron, gathering into band at top. Above hem at the bottom, make two clusters of tucks of three each.

### MODELS. SECOND SERIES. FOR EXPERIENCED WORKERS

- I. ROLLED HEM ; HEM STITCHING. Make a doll's apron of fine muslin, attach top to band with rolled, whipped gathers. Make two clusters of tucks of three each at the bottom and hem stitch the bottom hem.
- II. SLEEVE PLACKET. Make a taped sleeve placket as shown in the illustration
- III. MAKE A SLOT SEAM, using dress goods and finish with an arrow head. (b) Make a large cloak buttonhole.
- IV. MITRE EMBROIDERY and finish as shown in the illustration. (b) Match and join the same.
- V. EMBROIDERY: Make something small and useful—a doily, stock, collar—illustrating some style of embroidery, or make a model of the first series which will afford you the most new experience.

# Textiles and Clothing

## Part III



MAKING MEXICAN DRAWN-WORK

# TEXTILES AND CLOTHING

## PART III

### DRESSMAKING

The greatest obstacle to home sewing of any kind is the failure to provide suitable materials with which to do the work. To do good work—to make attractive gowns—the simple tools which the work requires must be provided. First, there should be needles and pins of the best quality and make. They should be fine and well pointed. The needle should be suitable to the material to be sewn and sufficiently large to carry the thread easily. A blunt or bent needle should never be used. Long or milliner's needles are preferred by many for basting.

**Good  
Tools  
Necessary**

A good supply of thread should be kept on hand—not too great a quantity, but the stock should be added to as it is used. There should be both silk and colored cotton, also twist for button holes, loops and arrow heads and knitting silk to sew on and finish feather bone.

**Thread**

Two pairs of scissors are required—one with long, sharp blades, and a pair of medium sizes for snipping machine stitches.

**Scissors**

Among the other necessary articles are a tape measure, cake of wax, pencils or tailor's chalk, tracing wheel, emery, lap board.

Canvas, scrim, or any like material should be kept in the sewing room, as these are invaluable for facings, linings of collars, cuffs, etc. Hooks, eyes, buttons, tape, linings, featherbone and shields are requisites not to be forgotten.

**Tapes**

Tape is constantly needed. Linen tape is thinner and makes a neater finish for some purposes than cotton tape. The bias tape or binding now kept by the larger stores is very useful for binding curved edges and for other purposes.

**Cutting Table**

If a regular cutting table is not available, the dining room table should be used. Skirts, bodices, ruffles, and bias bands should be cut on firm, even, and large surfaces. If cut upon the floor or bed and pressed on a coarse crash towel, the garment will have the undesirable home-made look.

**Pressing Board**

A good pressing board should be provided and if possible a sleeve board. In the process of garment making of any kind too much stress cannot be laid upon constant and careful pressing.

The ironing board should have for its outside cover a *finely* woven, perfectly smooth cloth, tightly stretched, free from wrinkles, and securely tacked.

Where there is gas, a small, portable stove should be kept near the sewing table with a medium-sized flat iron. Lacking gas, one of the single burner oil stoves may be used. An electric flat iron is especially convenient.

**Bust Form**

A bust form is a great convenience in fitting and





**PADDED BUST FORM**

(From Dressmaking Up-to-Date, Butterick Co.)

almost a necessity for one who does much home dressing. These may be purchased at department stores. Some kinds are adjustable, but it is always best to make a carefully fitted lining for it and pad out to the correct shape and size. The pattern should be one that extends well over the hips and heavy unbleached muslin may be used. After padding firmly, the front opening should be oversewed. Special care should be taken with shoulders and neck and the neck band should be carefully adjusted on the figure.

A padded sleeve lining is also very useful in making sleeves.

Dressmaking never should be begun until each needed article required for the work has been purchased. The sewing room should be in order; the machine well oiled and wiped before any work is undertaken.

Skill  
and  
Taste

If the finished garment is to be perfect, careful attention must be given to *every* detail of the cutting and making up. To possess mechanical skill alone is not sufficient. A successful garment depends not only upon the dexterity with which the worker manipulates the actual tools of her craft, but upon all her faculties and her power of applying them. She must have a comprehension of the laws of beauty in dress, construction, ornament, color, selection, economy. The artisan knows the technical part only, and looks upon each dress—each piece of lace and velvet—as so much material to be snipped and cut and sewed, copying from the fashion plate, making gown after gown alike. The artist, on the other hand, makes the gown

to suit the individual wearer, considering each dress no matter how simple—and the simpler, the more artistic—as a creation designed to suit the woman for whom it was planned.

People who study economy from principle will never adopt anything extreme in weave, or color, or make. These extreme fashions are never lasting; they are too conspicuous and are vulgarized by bad copies, while a thing which is known to be good and beautiful once will remain so for all time. Those who are beginners in the art of dressmaking should select plain designs until skill is acquired. The making up and finishing of new fabrics and new or untried methods are problems that often dismay even the most experienced dressmaker.

**PATTERNS**

The makers of good and reliable patterns are many. Always buy patterns of firms that make proportion of figure as well as fashion a study. These patterns state length of skirt, waist and hip measure and quantity of material required in all widths. Buy a skirt pattern with correct hip size, as it is much more difficult to change this than to alter the dimensions of a waist. Adjust the pattern to the figure for which the garment is to be cut and see that it is right in all of its proportions. Always follow the notches indicated in the seams of the pattern, and thus avoid putting wrong pieces together. Be sure that the pattern is

**Selection  
of Patterns**

placed correctly upon the material with the *straight grain* or warp threads of the goods running directly on a line with the *straight perforations* indicated in the pattern. Lay the entire pattern upon the cloth. This gives an idea just where every piece is to come out.

**What the  
Pattern  
Gives**

All patterns give one-half of the bodice and the skirt, from center of back to center of front. The plain waist pattern consists of back, curved side piece, under arm piece (sometimes these two pieces are in one) front, upper and under sleeve, collar or neck band. Some patterns allow for seams—others do not. Skirt patterns give only one-half of the front gore. The *seam* edges of front gore are marked by *one* notch near the waist line. The front or straight edge of the *first* side gore has one notch, and two on the back edge of side gore. All the gores may be distinguished from the edges of the back gores by the lesser number of notches. This is true of all skirt patterns. If the patterns are studied carefully, all skirt cutting becomes very easy.

The object of goring a garment is to take out unnecessary fullness at the top; reducing the weight, making the garment less clumsy, and giving a nicety of finish which could not be done in heavy material if all the goods were left to fit into a band. Skirts may be lined or unlined, gored or full.

#### SEVEN-GORED SKIRT

The style may vary with the fashion, but a well-fitting skirt should hang even around the bottom edge,

should fit easily around the hips without being strained or defining the figure too closely, or "ride up" when sitting, should flare slightly from hips to the bottom of the skirt, should not fall in between the feet, the back should fall well behind the figure. For heavy goods, as little material as possible consistent with the prevailing style should be used.

#### PLAN OF SKIRT MAKING

Shortening or lengthening of pattern if necessary.

Placing of goods.

Pinning on of pattern so there is no waste.

Cutting.

Removing and care of patterns.

Pinning, basting, or tacking of skirt to lining.

Joining of seams, fitting.

Stitching.

Pressing.

Finishing of seams and placket hole.

Making and putting on waist-band.

Marking length and finishing the bottom.

Fastenings, loops, braids, hooks and eyes.

To lengthen or shorten a skirt pattern, measure the figure and regulate the length of the patterns by making a fold in each gore two-thirds of the way from the top of the pattern if too long. This is for the simplest skirt pattern. The shape of the skirt may require two folds, one two-thirds from the top and a small fold near the bottom to preserve the outline.

If too short pin the pattern on the material, cut

**Lengthening  
or Shortening  
Patterns**

around the top of gore and on each side two-thirds of the distance from the top of gore. Unpin and draw the pattern down to the bottom and cut the required length. Except for wash material, do not turn a gored skirt up at the bottom to form a wide hem, as the fullness made by turning is hard to dispose of neatly and the right curve at the bottom of the skirt may be lost.

Another way to lengthen the pattern is to cut it in two, two-thirds the distance from the top. See that all pleats or tucks are exactly the same width and at the exact distance from the top or bottom of the gore, also that all seams are of the right length. A shorter skirt must be proportionately narrower.

**Testing  
Patterns**

It is well to test the skirt and waist patterns by using inexpensive materials, such as calico, gingham, or cheap lining. Cut, baste, fit, and make this as carefully as if it were the best cloth or silk. If the skirt and waist are satisfactory, the pattern will do duty for several seasons. The plain waist pattern is the foundation for *any* waist and many changes can be made easily with a well-fitting skirt and plain waist pattern as a basis.

**Cloth  
Patterns**

As paper patterns soon wear out, after a waist and skirt have been perfectly fitted, it is a good plan to cut an exact pattern of cambric, both skirt and waist, tracing seams and notching the parts. This will enable the home dressmaker to cut and make all ordinary dresses with little trouble and with but one trying on. It is always well to try on once, as materials differ in texture and a slight change may be necessary.

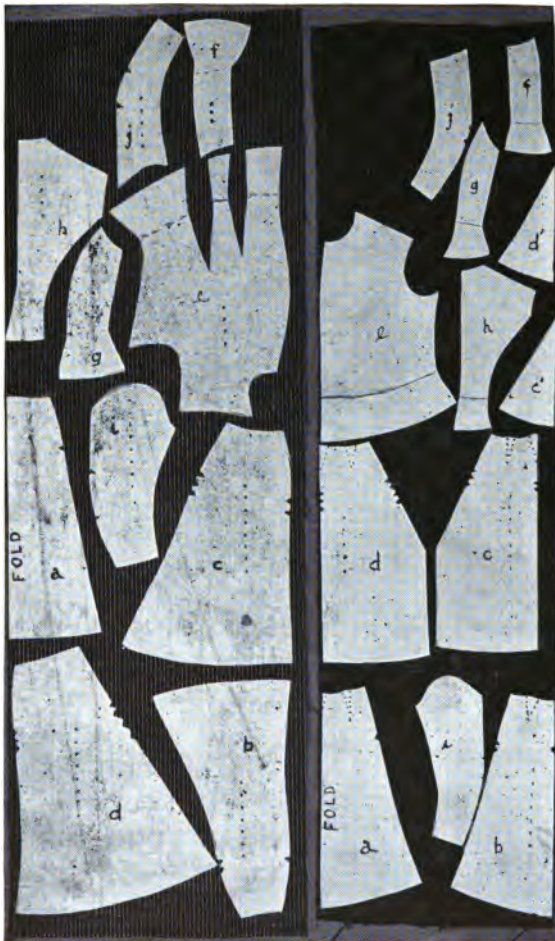

**PLACING PATTERNS**

At the left, on plain or symmetrical designs; at the right, on figured or napped goods. *a*—Half of front gore; *b*—Second gore; *c*—Third gore; *d*—Back gore; *e*—Front waist; *f*—Under arm piece; *g*—Side back; *h*—Back; *i*—Outside sleeve; *j*—Under sleeve; *c'* *d'*—Piecing of gores *c*, *d*.

**Placing  
Patterns**

If the material is plain, has no nap, or if the design is perfectly symmetrical, the gores may be alternated, the top of one gore coming opposite the bottom of the next. The half pattern of the front gore is always laid on a *lengthwise fold* of the goods. If the goods is wide, the other gores may be cut double with the cloth folded lengthwise. With narrow goods, the cloth may be folded end to end after the middle gore has been cut out, and the other gores cut double. Care should be taken that the line of holes in the middle of the gores runs exactly in a line with the warp of the material, i. e., parallel to the selvage.

If the goods has a figure, the design should run upwards. Any nap should run downward, except with velvet or velveteen, in which it should run upwards. With such goods, the gores if cut double must be placed on a lengthwise fold, with the lengths running the same way. If the goods is narrow, the gores may have to be cut single, reversing the pattern (turning it over) so that both pieces may not be for the same side.

**Pinning  
Patterns**

Pin the middle of the pattern to the goods and smooth towards each end, pinning securely at top and bottom. Avoid too many pins and pin carefully, otherwise the pattern will be displaced.

**Cutting  
Out**

After the pattern is securely pinned, cut out the gores, using long, sharp shears. Care should be taken not to lift the material from the table, not to have jagged, uneven edges, as both time and material will



be wasted in straightening them. Open the shears as wide as possible, taking a long sweep of the material, and do not allow the points of the shears to come together. Mark all notches with basting thread, tailor's chalk, or notch the goods if it does not ravel.

The back gores should be cut in the same way. They are usually wider than the front gores and may require piecing, which should be done along the warp threads.

Now remove the pattern, pin carefully all pieces together and fold as little as possible. The trinity—*pin, baste, press*—should be written in large letters in every sewing room, for much of the beauty of the gown depends upon these three.

To join the skirt, pin the side gores to the front gores, beginning at the top, with pins running across the seams, then begin at the top of the skirt and baste downward, allowing all unevenness to come out at the bottom. Baste straight and evenly, taking one stitch at a time. Several stitches should never be taken at once on thick or piled goods, as the side next to the sewer is apt to be fuller in that case. When all seams are basted, try on the skirt and make all changes necessary before stitching. Both the outside skirt and any under or "drop" skirt should be fitted as carefully as a waist.

**Joining  
the Skirt**

If the skirt is to be lined the lining should be made and fitted first, then ripped and the outside carefully basted on the lining, being well stretched over the lining, care being taken to have the warp of the outside

**Lined  
Skirt**

and the lining run the same way. This will prevent the lining from drawing the goods.

**Stitching  
Skirts**

A stitch of medium length should be used on all seams whether white goods or cloth. If the stitch is too long, the seam will "gap" and will show the thread; if too short, the seam is apt to draw. The line of stitching must be absolutely parallel inside or outside of the basting or the curve will be ruined. Use silk or the best cotton for stitching skirts and be sure that the needle is not too coarse.

**Finishing  
Seams**

After stitching, all bastings along the seams should be taken out by cutting the thread in several places. Never pull a basting the length of the skirt. The seams should be opened and pressed according to directions. The seams may be finished with a taffeta binding, overcast, stitched flat or notched, as the case demands.

**Stiffening**

If stiffening is used at the bottom of a lined skirt it should be fitted to each lining gore separately and securely stitched. A light weight canvas should be stitched to a heavy cloth skirt at the bottom, if several rows of stitching or braid are to finish the bottom of the skirt.

**Placket:**

The placket may be finished before the two back gores are pinned to the front, if preferred. If done before joining the gores the placket can be pressed better and the front is not so liable to be crushed. On the left side of the skirt sew an underlap of sufficient length to extend well below the end of the opening. Face the right side of the opening with a piece of the goods,

or tape not too wide, hem or cat-stitch to the skirt, and finish with hooks and eyes, loops, or any fastening that will secure the placket.

The skirt is now ready for the band, which should be narrow. Always cut parallel with the selvage and the length of the underlap longer than the waist measure, allowing for turning at the ends. The band should never be thick and clumsy and not too tight. Try on the skirt and fit the band carefully, marking the seam with pins, a line of basting, or chalk. Hold the skirt easy on the band and baste with small stitches, then stitch on the machine. If the skirt is too tight around the hips the plaits will fall apart at the back. If the skirt is stretched on the band the seams will not fall in a straight line. After the band is securely stitched and finished with hooks and eyes adjust the length by turning under at the bottom and pinning, after which baste all around and try on again to make sure that the length is correct.

**Putting  
on Band**

A gored outside garment should be finished with a true bias or a fitted facing, carefully stitched on. It is possible to finish the bottom of a simple house dress or thin skirt with a hem if the fullness made by turning is disposed of in gathers or fine pleats. A bias facing, however, is always preferable. If of heavy or lined goods the finish should be velveteen or braid the same color as the skirt. These bindings come in different widths and grades. Braids should always be shrunken by wetting and drying thoroughly; one wetting is

**Finishing  
the Bottom**

not enough. Velveteen should be applied loosely, so as not to shrink or draw after it becomes damp on the skirt.

**Applying  
Velveteen  
Binding**

The right side of the velveteen should be carefully basted with small, even stitches to the edge of the facing. It may be hemmed to the facing or machine stitched just inside the basting, which need not be removed. It is then turned, allowing a very narrow portion to show below the edge, and basted with close stitches, pressed, hemmed down to the facing by hand, or cat stitched without turning the edge. Be careful not to let the stitches show on the right side, nor let the binding twist or pucker. The joining of the velveteen should be near the seam in the back.

Another method is to cut off the bottom edge of the skirt a quarter of an inch from the turning line; apply the wrong side of the velveteen to the right side of the skirt, baste carefully close to the edge and stitch on the machine through velveteen, cloth, and lining (or facing) just inside the basting which is left in. The bottom of the raw edge is turned up, basted close to the edge allowing the velveteen to show a very little. The upper edge of the velveteen is secured as before by turning and hemming or catstitched without turning. The illustration shows this method of applying the velveteen which is first stitched to the lining and turned with the edge. This make a firm, rather stiff finish.

**Braid**

Braid is stitched on to the bottom of a skirt with

a narrow edge showing, or it may be applied like the velveteen, with a doubled edge at the bottom. The doubled edge will wear better.

Skirts that are to be washed and therefore which are very likely to shrink must be finished at the bottom with a wide hem—at least six inches—the fullness made by turning being disposed of carefully in pleats or gathers.

**Finish  
of Wash  
Skirts**



**APPLYING VELVETEEN BINDING**

If desired, the bias seam down the back of the skirt may have a narrow woven tape or selvage of thin goods stitched in with the seam. This strengthens the seam and prevents dragging. The skirt when finished should always be longer in front than in the back.

All cloth dresses demand every detail of finish to make them complete and able to stand hard usage, but simple house dresses and thin summer dresses do not require such careful finish.

#### SHIRT WAISTS.

##### Trace Seams

In planning a waist the same rules should be observed in placing patterns, etc., as described for skirts, except that the lines and seams should be traced with a tracing wheel or marked carefully. In making a waist of any kind care must be taken to cut all the pieces the proper way of the material.

##### Baste Lavishly

The difficulty of putting garments together after they have been cut properly is due to undue haste, lack of care in details and insufficient pressing. The apparently simple act of basting is really of primal importance, particularly in the making of a waist. One need never be afraid of basting too much or too carefully. Economize cloth and time in cutting, but use basting lavishly.

##### Altering Waist Patterns

The waist pattern may be made shorter by laying folds across both back and front. The fold across the back should be two inches above the waist line and across the front two inches below the arm's eye (in the back). Securely pin or baste the folds in the pattern.

If the pattern is of nearly the correct size it may be only necessary to make the waist shorter and smaller. The neck and arm's eye will seldom need altering. The sleeves may be shortened in the same way by laying folds in the pattern, above and below the elbow.

PLAN FOR MAKING A SHIRT WAIST

After the waist is cut, remove and care for the patterns.

Make the sleeves, cuffs and collar band first.

Make box plait on right or left side as liked by the wearer and hem on the other side or face.

Baste shoulders and under-arm seams.

Try on the waist, making all changes necessary by enlarging or taking up seams.

Pin for neck band and mark for seams.

Fit sleeves and mark places for seams.

Arrange fullness and place tape at back of waist line.

If the pattern is for a plain, one-seam sleeve with the cuff opening at the end of the seam, hem each side of the opening one or two inches from the bottom, gather the bottom between the notches, lay the gathers, baste the right side of the sleeve band or cuff to the wrong side of the sleeve, stitch and *press*, fold in a hem on all edges of the cuff, fold the cuff over on the wrong side of the sleeve, baste, oversew the ends of the cuff, *press* and stitch the cuff close to all edges. After thus attaching the cuff, baste and stitch the long seam of the sleeve and gather at the top between notches. The cuff is usually cut in the direction of the warp of the goods.

**Making  
Plain  
Sleeve**

The sleeve described is the simplest that can be made. If the sleeve is to open at the back and finished with a tape, with a placket, strap or fancy lap, the seam in the sleeve is stitched first and the cuff afterward adjusted.

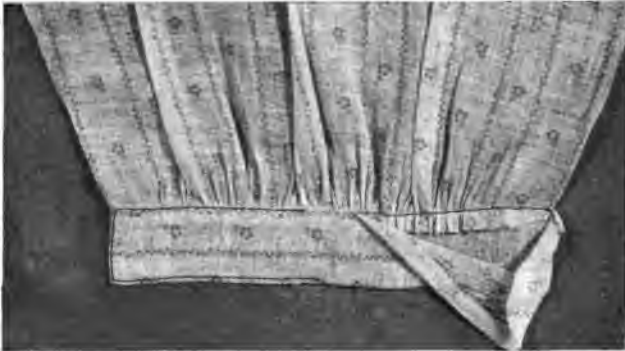

**PLAIN SLEEVE WITH CUFF. SHOWING GENERAL METHODS OF SEWING ON BANDS**

The box plait is made if desired and the under arm and shoulder seams basted when the shirt waist is ready to try on. Make any change in the seams necessary. The neck band is put on in the same way as the cuffs, sleeves sewed in, fullness arranged at the back and a tape placed at the waist line. Three hooks or other fastenings should always be placed at the back to attach to corresponding fastenings in the skirt band. The bottom edge of the waist may be finished by over-casting.



If it is desired to have the fullness cut away at the waist line in front, determine the length, allowing sufficient for a blouse, gather the waist at the bottom and sew the fullness on to a band. Sometimes this band is carried entirely around the waist.

**Bottom  
Finish**

The fit of the collar or neck band is very important in any kind of a waist. Both the front and the back may be cut higher than the pattern, as it is easy to cut off in adjusting and more goods cannot be added.

**Fit of  
Collar**

To the unskilled the simplest garment is sufficiently difficult. It is wiser to make two or three perfectly plain garments before attempting to make an elaborate one.

After the pattern has been tested, fitted and all necessary changes made, cut a pattern from the fitted waist of cambric or cheap *new* muslin and mark or trace all seams. (Never use old, worn-out sheets from which to cut a pattern.) After this permanent pattern has been made, do not change a single line.

If a plaited or tucked waist is to be made, all plaiting and tucking should be done first, after which the same order of making is to be followed for a plain waist. No waist should draw or strain across the bust. This is especially important in tucked or pleated waists. To guard against this tendency, a graduated tuck can be pinned on either side of the front, beginning with nothing at the shoulders and widening at the waist line. This is done before the pattern is cut and will allow for especially full bust. The fold should be *on a thread* of the goods.

**Tucked  
Waist**

**Full  
Busted  
Waist**

## LINED WAISTS

The plain, closely fitted, lined waist, with the curved back and side forms is the most difficult to make and requires the greatest nicety in handling from beginning to finish.

The pattern for a bodice of this kind should be of such a shape that in each part the woof threads will

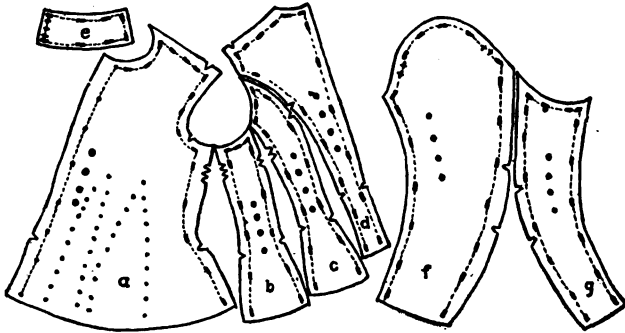

## TYPICAL BODICE PATTERNS

(a) Front. (b) Under Arm Piece. (c) Side of Back. (d) Back. (e) Collar.  
(f) Outside Sleeve. (g) Inside Sleeve.

go as straight around the waist as possible. This makes the warp threads perpendicular and will give almost a perfect bias on the current seams in the back. Do *not* cut the side forms out of *any* piece that is big enough, without regard to the warp and woof threads. If this is done, the threads in each will run differently and all ways but the right one. In a well-designed pattern the back forms should be nearly as wide at the

arm's eye as they are at the waist line. The swell of bust and shoulders should be accommodated by the back and front forms.

When material is to be cut on the bias be careful to have a *true* bias (the diagonal of a square) around the waist and up the front and back seams.

PLAN FOR MAKING FITTED, LINED WAIST.

Pin pattern to lining, cut out trace seams.

Baste all seams on traced lines.

Try on lining. Make changes.

Rip lining, baste on outside and cut by fitted lining.

Baste seams and try on. Make changes if necessary.

Mark the turn for hem down the front, face and mark for fastenings.

Stitch and finish seams. Put on featherbone.

Put on collar; sew in sleeves.

Finish.

In making a lined waist, the lining is cut, basted, and fitted before the outside is cut. After fitting, the lining is ripped apart and the outside cut by it. For all firm, heavy materials the lining should be slightly fuller than the outside, that is, the dress goods should be well stretched over the lining, just as in a lined skirt, and basted closely and evenly, the warp and the woof threads of the outside and lining corresponding.

In laying the pattern for cutting the lining, just as much attention should be paid to the direction of the threads as in cutting a striped or figured goods.

**Finish  
Lining  
First**

**Marking  
Seams**

All seams should be traced on the lining with the tracing wheel, with a slow backward and forward movement, making the perforations clear and distinct. Soft spongy goods that cannot be traced may be marked with a line of basting, tailor's chalk or by taking stitches with a pin along the line to be marked and twisting them in the goods. This will make holes that can be seen, but the twisting does not harm the goods. Always trace or mark the waist line, as this is the starting point from which to pin or baste. Bodice seams should never be begun at the top or bottom, but at the marks or notches that show the waist line, working towards the top and bottom.

After the lining is cut out, the seams should be based exactly along the traced lines, with seams out, when it is ready to be tried on.

**Making  
Changes  
in Straight  
Seams**

If the pattern has been cut or drafted by the correct bust measure, the back seams should never be changed. If possible, make all changes required by letting out or taking in on the straight under-arm seams, leaving the curved ones and the darts untouched.

**Pinning  
and  
Basting**

Pins should be used plentifully while the fitting is being done, but they should be replaced with regular basting as soon as they are removed. Do not be afraid of taking up fullness in the lining by darts crosswise at the top of the corset or where the fullness naturally falls in front or back. Such darts should be basted, stitched and pressed flat. If the lining is too short, it may be lengthened by letting out the shoulder seams.

After the lining is fitted, it is ripped apart, the outside cut, basted to it and the seams are basted, beginning at the waist line. Never use a long thread in basting and always use short, even stitches, especially where any curved seams are to be stitched on the machine. This rule must be followed invariably if puckering is to be avoided.

**Outside  
Cut by  
Lining**

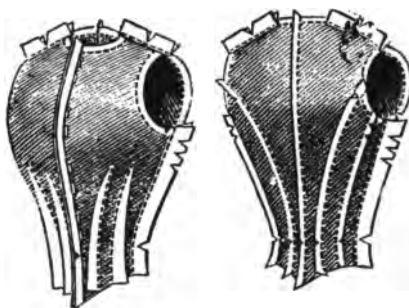

**WAIST LINING BASTED, SEAMS OUT**

The pattern at the shoulder seams should be shorter in front than at the back. In joining this seam, pin the two portions so that the ends of the seam meet exactly at the neck and arm's eye. In basting, stretch the front piece to fit the back, holding it in or puckering it if need be. Pressing will banish the pucker and give an easy seam that will hug the curve of the shoulder, as in a man's coat.

**Shoulder  
Seams**

**Fitting**

When the waist is on the figure, pull it well down to the waist line, pin the front linings together beginning with the neck, then lift the waist a little in front to give fullness and pin to the waist line. Mark for the hem down the front, finish the edge with a well-fitted facing under which is a thin bias strip of canvas interlining for buttons or hooks and eyes. Marks showing the position of fastenings should be made at this time.

**Fitting  
of Neck  
and Sleeves**

The neck and arm's eye should be fitted by making slashes in the curve—never cut around the curve. For the collar or neck band have a true bias of thin canvas or crinoline and draw it around the neck and pin with the ends *out*, towards the worker. (Never lap any edges of waist, belt or collar when fitting.) Mark on the waist where the lower edge of the neck band touches. Draw the sleeve on the arm, pin and mark where it sets right, seeing that the elbow fullness is in the right place and that it does not twist at the hand.

As in the lining, all changes necessary in fitting should, if possible, be made in the straight seams, as it is difficult to preserve the proper lines of the curved ones. The shoulder seams should be the last one to be basted.

After all faults are remedied, the seams are carefully stitched along the line or basting, the bastings removed, the seams pressed and finished. The last seam to be stitched securely should be the one at the shoulder. By leaving this open, all fullness can be smoothed upwards and any trimming can be let into the seam.



**BACK OF WAIST, WELL MATCHED**

**Boning** Sew in featherbone by cat stitching to the seam, first finishing the ends by button-holing. All seams should be stretched well when sewing on bones of any kind.

Curved seams should be notched every one or two inches at the curve and bound or overcast. This allows them to lie flat.

**Draped  
Waist**

In a draped waist the lining is made separate and not stitched into any seam of the outside except at the shoulder. In fitting the outside the back is pinned on to the lining firmly, then the front and finally at the underarm seams. The seams are then basted, the waist tried on again, alterations made, if necessary, seams stitched and the bottom finished with the lining, as desired.

Three eyes or other fastenings should always be sewed at the seams in the waist line at the back to secure the skirt to the waist, thus preventing it from sinking below the waist line.

**Finish  
of Bottom  
of Waist**

The finish of the lower edge of the waist is often a problem. If the waist is to be worn under the skirt, just how to finish or whether to finish it at all is a question. The first step is to trim the edges evenly. A line of stitching and simple overcast will show less through a close-fitting skirt of light weight material. When binding is used, it should lie perfectly flat, twice stitched and pressed well.

If the waist is to be worn outside the skirt, a narrow bias strip of canvas should be basted on the wrong side, the waist turned up over this as directed for



sleeve and collar finish. Over this a bias facing of silk may be hemmed or cat-stitched.

In spite of careful measuring and all care in cutting, the waist may not fit, owing to some deformity or peculiarity of the figure. Such figures require especially careful fitting and the hollow place should be filled out with wadding. This needs to be done with the greatest care and nicety.

**Fitting  
Irregularity  
of Figure**

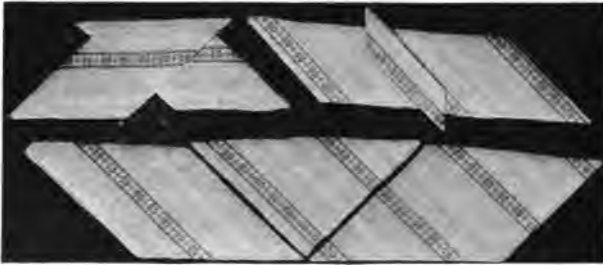

**MAKING BIAS STRIPS FOR FACINGS**

Avoid too frequent fittings. The bias portions of the bodice are liable to stretch out of shape and too much handling of the waist takes away the freshness. This is one reason why it is advisable to make the sleeves and collar first in order that the whole waist may be fitted at once and all alterations made to fit both sides. A perfect figure is the exception rather than the rule and the side that is not developed should be well fitted, whether sleeve or bodice.

## COAT OR TIGHT FITTING SLEEVES

**Altering  
Patterns**

If it is necessary to lengthen the sleeve, say two inches, cut the pattern at right angles to the lines indicated by the dots, above and below the elbow. The slashing should be done exactly at the same distance apart in the upper and under portions of the sleeve in order to retain the proper shape and size of the top and bottom. Separate the parts, allowing one inch above and one inch below the elbow.

To shorten the sleeve, lap the slashed part or lay a fold in the pattern instead of slashing. In either case, care should be taken that the fold or lap is of even width all the way across, so that the original shape of the sleeve will not be lost.

**Placing  
of Patterns**

Too much care cannot be taken in arranging the pattern of the sleeve according to the thread of the goods. Especially is this the case in the two-piece or coat sleeve. Generally the top part of the outside seam and the lower part of the same side should be placed at the edge or fold of the goods, so that the two run in the same straight line. In all cases, the foundation sleeve or lining should be cut and fitted before the outer portion is adjusted. Ample time should be given to the fitting and basting of the sleeve. The "set" of the sleeve is very often unsatisfactory because the cutting and original basting was done in a careless manner. Remember that greater care is required in sleeve making than in any part of the garment. Each sleeve is complete in itself and one must not deviate from the

other in size, arrangement or ornament, or general appearance. They should be cut, basted and fitted alike and if the arms differ in size or length the sleeves must be so adjusted as to conceal the inequality.

The sleeves should be made at the same time and before the cuffs, then the cuffs, puffs, or whatever special trimming is to be applied to them should be put on both sleeves at the same time. If the second sleeve is not made or trimmed until after the first is finished, it will be much more difficult to secure exactly the same effect. If it is impossible to complete both sleeves at one time, make the sleeves one day and the cuffs or trimming the next day.

In making the coat sleeves the general methods are the same, but each season brings out new styles which the maker will have to understand before proper making and finishing can be acquired. Always master the simple and standard patterns and the minor changes dictated by fashion—new fancies and effects—will not be difficult to acquire after a little experience has been gained.

The lining for both sleeves should be fitted and the outside cut by them.

After economical cutting, trace the seams carefully, and baste the outside to the lining, basting both uppers before the under sections. Join the under and upper parts by pinning and basting, the outside seam first, beginning in the middle of the sleeve and working toward each end. The outside seams should be begun at the

**Joining  
the Parts**

notch at the elbow, working toward each end. Where the sleeve calls for gathering the fullness should be distributed between the notches and the two portions of the sleeve should be secured at this point, before or after basting the upper or lower portions of each sleeve.

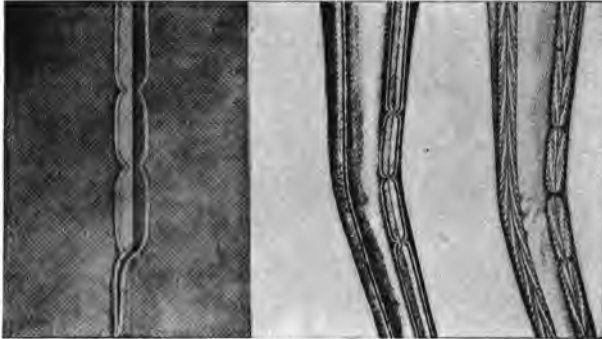

#### FINISHING OF SEAMS

Notched at Curves and Bound or Overcast.

Stitch the seams just outside the basting, then remove the line of basting along the seam and press. Trim off all rough edges. The inside seam is opened and notched at the bend of the elbow and an inch or two above and below and bound with silk binding ribbon or evenly overcast with twist or mercerized cotton.

#### Adding Cuffs

If an elaborate cuff or trimming is to be added to the sleeve, whether full or plain, it should be made separately and blind stitched to the faced sleeve. In case

the sleeve is gathered the fullness can be put into a narrow band, the exact size of the cuff, the cuff then sewed on the band.

In putting the sleeve in the armhole, be sure that both seams are at the same point, that both have the same amount of fullness at the top, and that the plaits or gathers are equally distributed from front to back. The sleeve should be held next to the worker and should lie easy from seam to seam at the under arm. Baste with close, even stitches or back stitch with coarse cotton or twist the same color as the waist. Stitch in the sleeves on this line of basting, keeping the armholes curved while the stitching is being done. Trim off edges and finish with binding or close over-casting. The most careful binding is clumsy compared to the overcast finish. Turn the seam toward the shoulder and hem to the lining over the shoulders. This will do away with the stand-up look that sleeves sometimes have.

For the sleeve finished plainly around the wrist, a piece of bias crinoline should be fitted at the hand. To do this, turn the sleeve *right* side out and slip the crinoline in the sleeve over the left hand and adjust by moving the fingers until the crinoline shapes itself to the sleeve perfectly, then pin and baste at the top and bottom. In this way the crinoline will be neither too short nor too loose and all wrinkling will be prevented. Turn the sleeve inside out and cut off the crinoline one-fourth of an inch from the edge, keeping a per-

**Putting  
in Sleeves**

**Finish  
at Wrist**

fectly true edge, turn the sleeve over the crinoline, baste the outside part of the sleeve and cat-stitch to the crinoline, then cat-stitch the crinoline to the lining. Remove the lower basting and press. A bias strip of silk sufficiently wide to cover the crinoline is hemmed at the lower edge and to the sleeve lining just above the interlining. Whenever it is possible to do so use the cat-stitch. It is a neat finish, easily and quickly done, takes less time than hemming, besides being less bulky.

If the bottom of a coat sleeve is to be left open at the back or slashed, an interfacing of light weight canvas will be necessary. Turn the outside portion of the sleeve over the canvas, care being taken to turn all corners at the slash, and curves, press and stitch, face after the stitching is done. It may be stitched better if the back seam is left open.

**Pressing  
Sleeves**

In the coat sleeve, both seams are curved and should be pressed on a curved board. A rocking chair inverted, with the rocker covered with soft cloth, makes a good board on which to press the curved seams of a sleeve.

**COLLARS**

The shaped, standing collar is worn with waists of all kinds and is always a popular neck finish. In a close-fitting collar made of heavy material an interlining of canvas or crinoline is necessary. The interlining should be cut one-fourth of an inch smaller all around if the collar is to be blind stitched to the waist.

If it is to be sewed to the neck, in a seam, the lining should be the same size as the collar at the neck. Baste this interlining to the collar material, cut out the corners of the material, and hem the extended portion to the interlining. The interlining should always be cut bias, whether the outside is bias or straight. Hem the collar lining to the collar.

To sew the collar to the neck of the garment, first pin, beginning at the back seam and baste towards the end. The lining may be left free at the lower edge and felled over the neck edge after the collar has been stitched to the garment, or the lining may be stitched in the seam, the seam pressed open and a bias facing of silk or light weight material hemmed on over the seam.

Putting  
on Collars

The beauty of collars and cuffs depends largely upon the exact turning of corners and finish of ends. These should never be left bulky or clumsy. If preferred, the lining and outside of collar may be seamed and turned. Place the right sides of outside and lining together, the interlining next to the lining, stitch around both ends and top of collar, then turn and press. These rules may be followed in making sailor or any lined collars. Collars made of all over embroidery should be faced with tape on the wrong side before the trimming is applied to cover the edge of ruffle or lace.

The plain or shirt waist pattern will do duty for many garments—corset cover, night dress, dressing jacket, etc. The upper part of the waist will answer for yoke pattern of different shapes.

## SEAMLESS YOKES

**Pattern  
for Yoke**

To make a pattern for a seamless yoke baste together the shoulder seams of the fitted waist pattern, place the upper part of the pattern on cambric or stiff paper, with the front of waist on straight edge or fold of paper, trace the shape of the neck yoke any desired depth below the neck line. The lower edge can be cut in any shape, the neck either high or low, round or square. This perfectly fitted yoke pattern can be used for a foundation for lace, velvet, ribbon, net, or any thin material. The circular yoke made of lace and ribbon or bias strips can be made to open in front or back. The strips of inserting and ribbon should be basted on the paper pattern and joined by fancy stitches or over sewed. The parts next the neck will need to be held fuller than the outside curve of the inserting.

All yokes to be worn under the gown should be made on a well-fitted lining. Never trust to pinning, basting, or hooking the yoke to the waist.

The finish of collar, cuffs, girdle and placket are hallmarks of good dressmaking. Well finished ends and corners, the careful adjustment of fastenings, shields carefully fitted to the arm's eye and caught smoothly to the lining—all these are little things that count for more than money spent in expensive ornament.



## PRESSING

The success of the finish of every garment depends upon the pressing, whether the material be heavy or light, cotton or wool. Garments are always pressed on the wrong side, when being made. The iron used should neither be too hot nor too heavy and the work should be done on a perfectly smooth, well-covered board. For pressing black or dark cloth, the cover of the board should be dark and free from lint, while a perfectly clean light cover should be substituted when white or light goods are to be pressed.

**Pressing  
Board**

The whole face of an iron should never be put down on a seam or any part of a waist, but the side or point should be used, care being taken *not* to stretch a curved seam. A small rolling pin, a broom stick, a chair rocker, or any rounded stick well covered can be used for pressing curved seams or sleeves. This lessens the danger of marking the seams on the right side. These are only makeshifts; a regular half round sleeve board should be obtained if much work is to be done.

**Placing  
the Iron**

In pressing, the iron should never be shoved or pushed, as in ironing. Only heavy materials require great strength. It is possible to press too much as well as too little. Whatever the material, pressing is work that requires to be done carefully and slowly. Allow the iron to touch only the center of the seam, the edges of the seam will not then be outlined upon the goods. Piled goods require infinite care. Uncut

velvet, crape, etc., should *never* be pressed with the iron flat on the seam. The seam should be opened carefully and over the rounded surface of the board, covered with very soft cotton flannel into which the pile can sink without being flattened. Run the iron with the pile, or the iron may be placed on the side or flat end and the seams drawn slowly along the edge of the iron the same way the pile runs—only the edge of the iron touching the edge of the seam. Corded seams should be pressed in the same way to avoid flattening the cord.

**Wet  
Pressing**

Very heavy cloths and chinchilla should have a small stream of water carried along the seam, followed by the iron; or the seam may be dampened by a soft cloth—very wet. This is the “wet pressing” used by tailors, which is adapted to the requirements of materials used by them, such as serge, tweeds, etc. Pressing on the right side under a damp cloth is apt to give marks if the cloth gets too dry or if the iron is too hot, but is necessary on finished wool garments.

Silk scorches easily and should be pressed very carefully with a cool iron, light in weight.

Some light colors fade or change in pressing. Try a piece of the goods before pressing the garment. If the color does not come back when cold or when exposed to the light, do not use a hot iron on the garment.

## CONSTRUCTION AND ORNAMENT FOR DRESS

Many of the principles governing architecture and art apply equally as well to art in dress. Both in architecture and dress, construction should be decorated—decoration should never be purposely constructed. It is by the ornament of a building that one can judge more truly of the creative power which the artist has brought to bear upon his work. The general proportion may be good, the mouldings accurate, but the instant ornament is attempted, the architect or the dress-maker reveals how much of an artist he is. To put ornament in the right place—where it serves a purpose—is indeed difficult; to render that ornament at the same time an added beauty and an expression of the desired unity is far more difficult.

**Principles  
of Ornament**

All decoration should be planned to enrich—not to assert. All jewelry or ornament should form a note in the general harmony of color—a decorative touch to add beauty and to be subordinated to the object decorated. It should serve the purpose of seeming to strengthen the whole or to protect the parts receiving most wear. Ornament is everywhere attempted. We see ornament at every turn—good and bad alike—in our homes, on clothes, linen, and kitchen utensils. Carlyle tells us that “The first want of barbarous man is decoration.” We have no record of when this need was felt first. Primitive man after supplying his actual needs, seemed to develop a longing for the beautiful, so he ornamented his own body, scratched rude patterns on his tools and weapons and gradually devel-

**Purpose of  
Ornament**

oped the artistic sense. This love of ornament dates back to the beginnings of the human race and there are no records of a race or a period devoid of it.

**Errors in  
Ornamentation**

We see gowns totally lacking in good results because too much has been attempted. The wearer has not considered the effect as a whole, but has gratified her liking for a multiplicity of ornaments and color which, perhaps would be good in themselves, if applied separately, but which becomes an incongruous mixture when brought together on one garment.

Garments which seem to have required great effort in the making and which appear complex in construction should be avoided, for the effect is not pleasing. The gown should set off the wearer, not the wearer the gown.

To avoid committing errors against good taste it is essential first to consider the use of any garment and see if it answers the purpose for which it was designed. If any part appears meaningless, this is a sure indication that it is wanting in grace and beauty. The ornament should harmonize with the materials, use, and construction of the object to which it is applied. The color must be massed with effect and detailed with care.

**Embroidery**

There can be no ornamentation equal to that which is worked into the material, such as embroidery. The design should be appropriate in form and color and always conventional. Flowers are used most frequently for embroidery and passementerie and the

simple, single flowers are the most effective, such as the daisy, the wild rose, and the flowers of the lily family. These simple flowers are the best because they radiate from a central point, have strong forms and decided proportions, can be most fully expressed in a few stitches requiring the fewest shades of color, and are admirably adapted for amateur workers.

Old Indian stuffs, jewelry, and enamels are rich in suggestions of conventionalized flowers. The simple, single flowers are repeated constantly, the daisy appearing to be the favorite in these beautiful ornaments. The most beautiful of all conventional flower work, jewel studded, is found in samples of work of the fifteenth century. They simple suggest the forms of nature. The repetition of the same flower in all its aspects is more pleasing and less tiresome to the eye than a variety of flowers or figures.

**Flowers  
as Ornament**

We find upon analysis that the simple forms are the basis of all decorative art work. Geometrical designs and arabesques are the most difficult, requiring the most exacting and careful work. Narrow bands, braided, outlined, or chain-stitched in simple designs are effective, easily done, and wear well. Braids and any of these stitches may be combined, making durable and effective trimming for sleeves and neck. These simple designs are also appropriate for children's frocks. The French knots are ornamental and durable. All embroidery and passementerie should be rich, close, and continuous. It should not be cut up into

**Geometrical  
Designs**

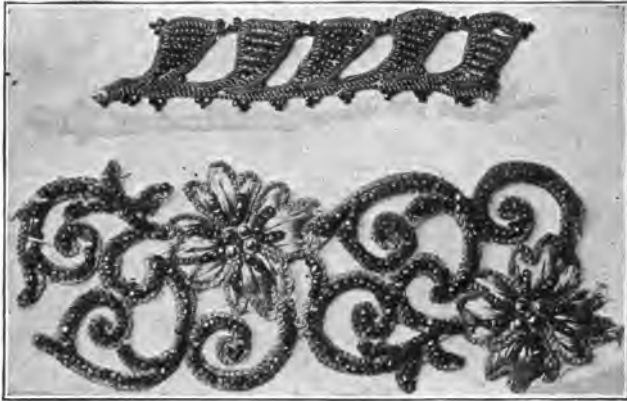

PASSEMENTERIE OF GOOD DESIGN



POOR DESIGN, WEAK CONNECTION

pieces and sewed on where it does not serve, or appear to serve, a purpose.

**Passementerie**

There is very little passementerie that is at all suitable for forming edges, as it is not sufficiently substantial, but when it can be found firm and of the right shade it is one of the most beautiful ornaments to edge neck and sleeves. It may be allowed to extend beyond

the dress material, so that the flesh tints may show through the design, thus gradually softening the outline. Often a narrow passementerie can be found with one strong edge and a good border can be made by joining the two. This cannot be done where the pattern is united by a band running through the center of the ornament.



JOINING NARROW PASSEMENTERIE TO FORM A BORDER

A band of velvet or cloth embroidered in outline stitch and French knots of same shade as the garment is a satisfactory edge. Except for yokes, the knots should always be held together with the outline edge.

The rich silk braids and passementeries are made of silk wound or woven over cotton and should be used only on dresses which are not intended for hard wear. Such trimmings are, of course, inappropriate on serges and homespuns and soon become shabby if given much rough service.

Laces, like all trimmings, have defined limits within which they should be used, though they are often worn indiscriminately. Machine made laces, often good in

**Bands**

**Use of  
Laces**

make and design, are now very common, but the best machine-made laces are not cheap in price.

**Design of  
Lace**

Handsome lace should be applied rather plainly, as the pattern is often lost in the gathers. Fine laces are out of harmony with heavy or coarse materials. When lace is desired for flounces that with running patterns which neither advance nor retreat, except in the folds which may be made, will be found most pleasing. Distinct objects, such as baskets, crowns, vases, etc., which suggest weight, are unsuitable patterns for so light a fabric as lace.

**Placing of  
Decorations**

Attention to details is essential in the placing of these decorations, as in the selection or making of them. The worker should take into consideration the shape and size of the bands or pieces of trimming and should note carefully the chief characteristics of the design and above all the junction of leaves, flowers, arabesques, especially in the finishing of the corners of collars and cuffs.

**Simplicity  
and  
Harmony**

Those at all skillful with the use of the needle can attain the most beautiful and artistic results if right laws in color and design are adhered to, even by the use of the simplest stitches, for the beauty of dress lies not so much in the richness and variety of material used as upon simplicity and harmony—a fact too often disregarded.

**The Bow**

Perhaps no ornament is more abused than the bow. In order not to appear intrusive, ribbons require the most delicate handling. The only excuse for a ribbon



as an ornament is when it makes a pretense of tying. When used as a sash where folds or gathers are confined, the tone of the ribbon should, in general, vary scarcely from that of the dress.

Whatever the ornament used, whether embroidered band, a ribbon, a cord that laces, a diamond pin, or a jeweled buckle, though it may possess great intrinsic value and beauty, it cannot be considered of real worth as an ornament unless it fulfills the most important condition—fitness of place.

**Fitness  
of Place**

Although the art of dress admits of innumerable variations, like all other arts it is subject to the three rules of beauty—order, proportion and harmony.

Ornaments are appropriate on the hems or edges of garments where it serves the purpose of strengthening and protecting the parts most worn, and not simply where fancy or fashion dictates.

The natural fastenings and fold centers should be along the axis or center of the body. Any jewelry, buckle, brooch, or ornament used to fasten, secure, or strengthen these centers or to hold bands of embroidery, collar, or folds together should be sufficiently strong to serve the purpose. There must be a reason for position and the purpose of its use must be apparent to satisfy the eye. The eye is unconsciously and irresistibly drawn to these natural centers and demands some object there on which to rest—some substance from which the fold emanate—some reason for their detention. If this ornament at the throat or waist

**Natural  
Centers**

fastening collar or holding folds by a girdle or clasp is omitted, the eye is disappointed. This does not mean that the ornament, jewel, passementerie, or embroidery should always be placed in the axis or central line of the figure—this may be carried too far. Slight irregularities often give an effect to hat or gown that is charming.

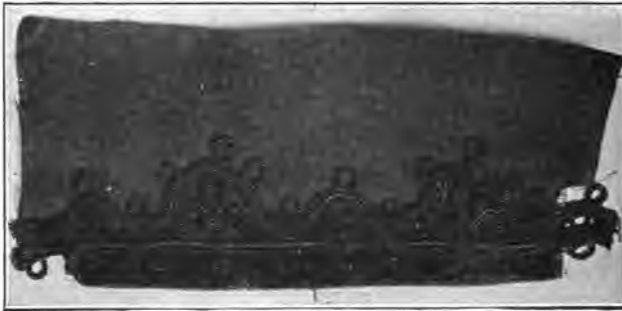

PASSEMENTERIE COVERING FACING

**Trimming**

Remember that trimming is not intended to cover up, but to beautify and strengthen. When, for economy's sake, it is used to cover worn places or other defects, it must be selected and applied with great care or it will loudly proclaim its mission.

Trimming should mean something—whether jewelry or passementerie. Bands that bind nothing, straps, bows, buckles, or pins that confine nothing offend the taste. A girdle should seem, even if it does not, to belt

in fullness ; it has no use on a close-fitting, plain waist. No draperies should be invisibly held ; supply some apparent means of confining the gathers. To preserve the lines of the figure there should be unity in the dress. A tight-fitting skirt below a gathered waist or a full, gathered skirt below a plain waist gives the appearance of two portions of the body instead of the oneness desired.

**Unity in  
Dress**

The figure should never be cut across, either above or below the waist-line with contrasting colors, different shades of the same color, or bands of different texture. Below the waist-line the figure should suggest the elements of strength and these horizontal bands cut the lines of the figure at an angle of opposition, destroying the rhythm and grace of the lines.

Much experience is required in placing horizontal lines of ornament on a skirt effectively. In general, rows of tucks or ornament should diminish in width from the bottom towards the top. The plain spaces should be greater than those ornamented. When ornament gives absolute evenness of space division in skirt or waist the effect is apt to be monotonous and unsatisfactory.

The natural places of support for garments are the neck, shoulders and waist. Ornamentation which emanates from these centers or when used for borders, if appropriate in design, is usually successful.

## ORNAMENT OF TEXTILES

In addition to ornament added to garment, the ornament in the textile itself must be considered.

**Appropriate  
Designs**

Textiles may be beautiful in weave, but spoiled by the design. Quite as important as intrinsic beauty is appropriateness of pattern. How often do we see woven on our curtains, carpets, and garment materials fans, bunches of roses tied with ribbons—bows with long, fluttering ends—landscapes, snow scenes, etc. Nothing is beautiful out of its place. A fan suggests coolness and grace of motion, but woven in our textiles it gives the same impression as a butterfly mounted on a pin—something perverted, imprisoned, or robbed of its natural use. Nothing is or ever can be beautiful without use—without harmony. Decorations on textiles are not to tell stories. There is a difference between landscape painting and using landscapes as a motive for decorating textiles or pottery. In one case the aim is to annihilate surface by producing the impression of distance; in the other, the object is to glorify the surface only.

**Advantage  
of Plain  
Material**

For the woman of limited income it is wiser to select plain material of good texture and weave. Such material is never conspicuous, can be made over, and is always restful and may be interesting. Any good textile must impress itself upon the mind by its suggestiveness and beauty of color. There is a difference between what may be called artistic and decorative

embellishment of textiles. Each has its place in the world of beauty, but one is the poetry, the other the prose of the art.

There is a dignity and restfulness in plain material which is never obtained by varied patterns. When a stripe is used to vary the material, the style of the textile is changed, elongated if the stripe is vertical, and widening if it is horizontal. If the main stripe is cut at right angles with a second stripe, the textile appears more complicated and repose is lost. The same is true of checks, but no pattern is more distracting than large plaids, especially when used for waists, because the regularity of the design renders very conspicuous any inequalities in the shoulders or bust, and the great variety of colors detracts from the dignity of the dress. With small checks and narrow, self-colored stripes the effect is different, causing the texture to appear only shaded and not destroying the unity.

**Stripes**

On garment fabrics the ornamentation should be flat, without shadow or relief. The pattern must enhance and not mar the figure. If flowers, foliage, or other natural objects are used for the designs, they should be conventionalized—not direct copies of nature. A figured textile requires more careful planning than plain material. It may be beautiful when used properly, but it will appear hideous if distorted in the making. A conventional fleur-de-lis pattern, or a long dash which appears and disappears when used in long,

**Conventionalized  
Designs**

graceful folds, adds to the apparent height. These same figures wrongly used spread out awkwardly or become distorted.

**Size of  
Design**

The size of the design should be regulated by the material—small patterns being used for close, thick fabrics and larger designs, with more delicate colors, for thin material of open texture. Thick, heavy fabrics require rich, warm colors and the pattern likewise should be rich and decorative. Velvets, velveteens, and heavy cloths for dresses are beautiful in themselves and should not be marred by patterns or trimmings.

Spirals or curved lines running crosswise on textiles distort the natural curves of the figure by making seeming undulations where none should be and accentuating the prominence of hips and bust. Such patterns should not be used in folds.

**COLOR**

**Texture  
and  
Color**

Much is to be considered in choosing colors and it is folly to suggest a particular shade for a person without taking into account texture of the textile. Though the color may be good, the weave may destroy what might otherwise have been a success.

Not only must color in itself be studied, but quality of color in textiles as well. A shade of red, for example, in dull silk or lusterless material may be most unbecoming for a woman of a certain type, while it may be worn successfully if made in rich velvet or glossy silk.

Some women maintain that they cannot wear green, but nearly all can dress becomingly in this color if the shade and texture is selected carefully. The same may be said of other colors for the many variations should be taken into consideration.

The average woman in selecting materials for gowns or house furnishings is apt to be influenced too much by details, as she would judge the merits of a fine piece of needlework, hence the value of good, broad color schemes fails to appeal to her. The chenille curtain, perhaps, suits her because it is full of complex decoration.

After having determined the prevailing color of a costume, the details should be in *harmony*, rather than in *contrast* with it. Different tones of one color are more satisfactory than striking contrasts, and even strong patches of light and shade of the same color should be avoided, as well as patches of crude and vivid color. The pleasing contrasts found in nature cease to be happy when attempted in textiles.

Harmony  
Not  
Contrast

Use few colors, avoid bright shades except in small quantities. All bright colors should be placed near the face, rather than on or near the bottom of skirts or the edge of sleeves. Avoid strong contrasts; the brighter the color and the greater the contrast with other colors, the louder and cruder will be the effect. "No color harmony is of a high order unless it involve indescribable tints."

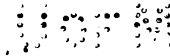

## CHILDREN'S CLOTHES

### Infants' Clothing

Plainness, purity, softness of texture rather than elaborate ornament should be the main consideration for infants' clothes. The finest and softest of French and Scotch flannels, French linen, dimity, nainsook, and India silk are always dainty and they should be made up very simply with little trimming, but that of the finest.

Hems and seams should be small and neatly done with, perhaps, the daintiest beading inset by hand and feather stitched. Hemstitching is always beautiful, but makes a weak spot which is apt to give out in the constant laundering necessary for children's clothes.

The skirt and shirt made in one piece, with sleeves to slip into the little outside garment, both to open down the back so that all may be slipped on at the same time without worry to either nurse or baby, will be found a great convenience.

### Stockinet Undergarments

Stockinet or webbing, all wool, partly wool, or all cotton, is preferred by many to the plain cloth. The cotton is non-shrinkable, easily made, and finished. This garment fabric has reached such a high degree of perfection that for infants and children of larger growth nothing better can be desired for shirts, skirts, drawers, and tights. It may be had in either light or heavy weight, is easily laundered and elastic, having all the qualities desired in undergarments. Garments made of this material in the manner described give per-



fect freedom for all organs, besides evenness of covering for the body and lightness of weight—all important considerations in infants' and children's clothing.

There should be the same simplicity in construction and material in the garments of children of larger growth. The design should be smaller, more realistic and the color brighter than for grown people.

For children's dresses, the pretty gingham in small checks, chambray, dimity, serge, flannels, cashmere are appropriate and serviceable.

Children's  
Dresses

In making up these simple materials nothing better can be suggested than the plain, straight waist, fitting easily, to which a full skirt is fastened. The sleeves may be of any fashion to add variety. Such a frock is simple and dignified and has a certain archaic beauty and quaintness that the huge, ugly collars and like ornament can never give.

With the plain body the grace of the childish form is not lost. The body may be short or long, with the trimming at the bottom or edge of the skirt. The gathers fall in long lines or folds, no element of opposition destroying the rythm and grace of the figure contour, when the trimming is placed at the bottom of the frock instead of several bands dividing the skirt.

The waist should always be wider in front than in the back. The discomfort and injury caused by ill fitting garments, graded according to age instead of according to size, thus restricting the expansion of the chest and the play of the lungs, cannot be estimated.

With the proper kind of frock a child can indulge in any game without becoming in the least disordered. Dresses for little girls may have drawers made of the same material, thus permitting them the same freedom as the boys. The life of the child is play. Unfortunate is the child whose clothing is too good to play in. Of course there should be frocks for gala occasions. Children are sensitive to color and receive much innocent enjoyment from being prettily dressed. A child may be made unhappy and timid by ugly clothes, but plainness need not mean ugliness. There are many artistic and simple patterns now being put on the market and many of the ready-made frocks found in the best shops are satisfactory.

## CARE OF CLOTHING

Ruskin says, "Clothes carefully cared for and rightly worn, show a balance of mind and self respect."

The freshness of gown or wrap may be preserved by the little attentions bestowed upon it each time it is worn, which take but a few minutes and mean so much in all departments of dress. By carefully brushing and shaking into folds, removing all spots, hanging right side out, picking and pulling straight flowers, bows, and ribbons as soon as removed, adding buttons and taking up dropped stitches when needed,—all these little attentions if given promptly will keep a wardrobe fresh and in good order. New braid on the bottom of skirts, sponging and pressing, little alterations and addition of new trimming to collar and cuffs, will help to preserve the original freshness of the gown and cause the wearer to appear well dressed.

**Little  
Attentions**

Waists should be turned wrong side out when removed and allowed to air near a window. Shields should be cleansed with alcohol and water. Ribbons should be rolled up immediately when taken off and if treated in this way will last much longer and look much daintier.

Clothing if moist and dusty and tossed into a dark corner of a closet or trunk can never appear fresh again, and will betray the character of the wearer. It is not the wearing of clothes which tells so sadly upon them, but the manner in which they are cared for. A few garments nicely made, well fitted and properly

cared for are far preferable to twice the number of inferior quality and make.

**Ruffled  
Skirts**

Skirts of thin material having ruffles around the bottom should be hung upside down by loops sewed under the ruffles at the seams. By hanging in the opposite direction from which they fall when worn, ruffles regain their freshness.

**Packing  
Away  
Clothing**

All clothing for the season should be put away in perfect order to be ready for any sudden emergency which may arise. No clothing of any kind should be stored for the season without thorough cleaning and repairing where necessary. Garments that are outgrown should be disposed of, instead of packing them away. Wool garments should be carefully brushed and hung in the sun to remove and destroy any eggs of moths which may be present. They may be hung in tight cotton bags or packed in tight boxes with all openings posted over as a protection against moths. Tailors' boxes which come flat are not expensive and are useful for this. They should be plainly labeled with their contents.

**Folding  
Garments**

To fold, lay all articles on the bed or table and fold on the seams if possible. Particular attention should be given to sleeves and collars. Coat lapels should be turned to lie flat, collars turned up, and the coat folded directly through the center seam.

Skirts and coats with bias seams are not improved by hanging as the bias parts are apt to stretch out of shape.

No clothing should be put away for the night, even, without first removing all steel pins, as the least dampness may cause rust spots.

**Remove  
Pins**

Clothes forms and hangers are so inexpensive that every gown and coat should have its own. Skirts should be hung exactly on the form and no part of the band should be allowed to sag.

**Hangers**

If fancy waists are put in drawers or boxes, they should have the sleeves filled with tissue paper and the collars and bows should be pulled straight.

#### CLEANING

Large garments require the greatest care in handling and in order to be done successfully, they should be sent to the professional cleaner.

All stains and spots should be removed as soon as possible. Fruit and wine stains may be removed by stretching the fabric over a vessel and pouring boiling water through the cloth from a height of a foot or two. The water *must* be boiling.

**Fruit and  
Wine Stains**

Ink stains can be taken out of clothing by dipping the cloth in milk, squeezing the blackened milk into one dish and dipping immediately into clear milk until the stain has disappeared. Then finish by washing the cloth in warm water and in soapy water to remove the fat in the milk.

**Ink Stains**

Iron rust may be removed from linen and cotton by using lemon juice and salt. Wet the spot with the juice of a lemon, cover with salt and lay in the sun,

**Iron Rust**

repeating the operation until the stain is removed, then rinse out the lemon and salt thoroughly. This of course cannot be used on colored fabrics, as it fades the color.

**Grease Spots**

Grease is one of the worst foes to garments and the greatest care is needed to remove such spots from delicate fabrics. If not done at once, the dust and grease together often prove ruinous. When the color and fabric will not be injured by it, warm water and soap is the best agent, otherwise absorbents may be used. French chalk or magnesia powdered, placed upon the spot, and allowed to remain for a time will often absorb the grease effectually. If the first application is not effective, brush off, and apply again until the spot disappears. Where water can be used without injuring the cloth, the chalk or magnesia can be made into a paste and spread over the spot. When dry, brush off with a soft brush.

In removing fresh grease spots, blotting paper with a warm iron may often be used effectively. If the heat changes the color of the cloth, the iron should be held above the goods.

**Blood Stains**

Blood stains may be removed by making a paste of starch and applying it to the spot. Several applications may be necessary.

**Solvents**

Only the best and purest benzine, naphtha, gasoline, and turpentine should be used for cleaning garments. For removing paints from coarse cloth, pure turpentine is useful, while for silks, velvets and woollens, benzine, naphtha and gasoline are to be preferred.

The secret of success in the use of any of these cleansing agents lies in immersing the garments in *large quantities* of the liquid. Not less than a gallon should be used for a waist and two gallons will do the work far more satisfactorily. An effort should be made to remove all the worst spots before immersing the whole garment. Those which have not disappeared should then be marked with white thread, colored thread may leave a mark. It is a good plan to enclose the spot with a line of basting. Soak the garment for some time in the liquid, then soap all spots thoroughly and rub gently between the hands until they disappear. Finally wash and rinse the garment in clear liquid and hang in the open air until all odor has passed away. Soap may be used freely with gasoline with good effect. Some professional cleaners use a little of the strongest ammonia in their gasoline tanks. The goods should be shaken well and all folds pulled out straight with the threads of the goods. Velveteen, corduroy, and like piled fabrics can be cleaned successfully if not too much worn, but no amount of cleaning will restore the pile that is worn off.

If allowed to stand until the impurities have settled and the clear liquid poured into clean bottles, it may be used for a number of times. This should always be done in the open air.

Chloroform may be used for cleaning the most delicate silks, though this is rather expensive.

Whenever any of these liquids are used to remove spots alone, the spots should be placed upon a soft pad of several thicknesses of old cloth or blotting paper to

**Cleaning  
Garments**

**Soap and  
Ammonia  
with Gasoline**

**Absorbing  
Pad**

absorb the surplus liquid and the spot should be rubbed from the outside towards the center. A hole may be cut in very soft cloth or blotting paper and placed around the spot to absorb the solvent around the stain and prevent the dark ring being formed. The cloth should be rubbed lightly and briskly until it is dry. If the fabric is light colored, a sponge or a soft piece of light cloth should be used, while for dark fabrics, the cloth used for rubbing the spot should also be dark and free from lint. The rubbing should be done lightly so as not to wear or injure the texture of the fabric. The blotting paper or cloth underneath should be changed frequently until the spot has entirely disappeared.

**Cleaning  
Velvet**

Velvet hats and bonnets, after all trimming is removed, may be cleaned by repeated dippings in benzine or gasoline. The vessel used should be large enough to hold a sufficient quantity of the liquid to completely cover the hat. Of course all dust should be carefully brushed off and all folds ripped and loosened before putting the hat into the liquid. The secret of success lies in having the article entirely free from dust and using a large quantity of the benzine or gasoline.

**Before  
Sending to  
Cleaners**

Before sending out garments to be dyed or cleaned, be sure that they are in good condition. All worn places should be mended carefully and all buttons should be removed. Garments that are ripped should have all cut threads pulled out and be free from dust. Dust silk fabrics with a piece of clean flannel and woolen material with a brush or broom.



**REPAIRING**

Fabrics are so much cheaper and so much easier to obtain that patching has almost become one of the lost arts. The twentieth century woman feels that her time is too valuable to be spent in mending the old clothes and that she can better afford to buy new. However that may be, no one disputes the utility of mending. Like so many other duties, mending is half done when well begun. A well made garment of good material should not be discarded when slightly worn, for a patch well put in or a neat piece of darning detracts in no way from the value of a garment and may even be a work of art. The children's clothes particularly should be kept in good order, for they are made uncomfortable by wearing garments that are out of repair, to say nothing of the demoralizing effect upon their characters.

**Economical  
Mending**

Laundering is the great ally to tears and not only doubles the size of the hole, but pulls the threads apart so that it is impossible to make the mended place neat and smooth, therefore all clothing should be mended before washing. Stockings and woven underwear are much worn by the rubbing on the washboard and thin places going into the washing frequently come out as holes, so that it is true economy of effort and time to "run" or darn the thin places before they are worn through. It requires much less time and the garments last longer.

**Laundering  
and Repairs**

It is a good plan, especially in knees of stockings and knitted underwear, to baste a piece of fine net over a worn or broken place and darn over it. (See Darning.) Thread used for darning should be as near as possible the size of the threads in the garment. Darning cotton, linen, wool, and silk of all shades can be bought, so that the problem of matching is no longer a difficult one.

**Boys'  
Trousers**

In mending the knees of boys' trousers a round patch should never be used. The seams should be ripped and the piece set in then, if the seams are pressed well, the patch will scarcely be noticeable.

**Sleeves**

When bodices are worn under the arm, rip the seams and set in a new "under arm" piece. A good plan for one whose dresses are apt to wear through quickly is to have the under arm pieces and the adjacent parts of the front made of two thicknesses of the goods; then, as the outside wears through, the edges can be hemmed down or taken into the seam.

**Table  
Cloths**

When table cloths begin to wear in the middle fold or along the edge of the table, a few inches cut off one end and one side of the cloth will change the fold and the place where it falls over the table and give it a new lease of life. If the hem is turned down once and cat stitched, it will resemble the selvage more than a twice turned hem.

**Lengthening  
Garments**

In repairing or lengthening garments that have become too short, much can be done by adding to the bottom of the skirt and sleeves material of different

texture. A cloth or serge skirt may be lengthened by facing with velvet of the same shade, covering the line of sewing with cord, braid, or passementerie of the same shade or black. There should be an under-facing of light-weight crinoline to make the bottom of the skirt firm and to give strength. The same facing and passementerie may be used at neck and sleeves.

Thin gowns of lawn, dimity, etc., can be lengthened with a faced or extension hem, the line of sewing to be covered with feather stitch or any of the fancy stitches of white or colored thread. If the lawn or dimity has a colored figure, the embroidery silk or cotton may match this. Under skirts and drawers may be lengthened in the same way or rows of tucks may be added.

**Extension  
Hem and  
Tucks**

In waist repairing, the sewing silk should match the material. Set the patch into the seams when possible and trust to careful pressing. If the material begins to wear near the end of the bones, cut off the bones an inch and take in the dart or seam. If the silk wears off around the hooks and eyes, move them along ever so little. Make a virtue of worn out seams by taking them in and covering them with fancy stitching. If the garment is lined, the outside should be carefully basted to the lining before stitching to take in the seam. It has been said that silk waists are serviceable as long as the upper parts of the sleeves remain good.

**Waist  
Repairing**

If garments have not been well cared for from the first and beyond a certain point, "making over" is poor

economy. Never attempt cleaning and making over old clothes unless the material is good enough to make it worth while to do the work well.

**Mending  
Blankets**

The mending basket is an important adjunct of mending and should be well supplied with darning cotton of all colors and sizes, good English tape, black and white, of different widths, linen tape, bias tape, different kinds and sizes of needles,—sewing, darning, shoe, carpet, and tape needles.

**Use of  
Tape**

For repairing bands and facings, where buttons have been torn off by wringer or iron, and for strengthening weak places, tape is invaluable. It saves the time required to turn in the edges of the cloth and is less clumsy and bungling.

**Use of  
Judgment  
in Mending**

The mender should use good judgment as to the amount of work to be applied to each garment. She should substitute the machine needle whenever possible and not put tiny stitches by hand into half worn garments or in unseen places. Ripped tucks and bands can be sewed in a few minutes on the machine. Serviceable darning can be done on the machine.

Before putting away freshly laundered clothes it is a good plan to take out the clothes already in the drawers and lay the ones washed last on the bottom, thus all garments will wear alike, each article in its regular turn.

**BIBLIOGRAPHY**

- Home and School Sewing, Frances Patton, (\$.60, postage 6c).  
School Needlework, Olive C. Hapgood, (\$.75, postage 6c).  
Sewing Course for Schools, Mary Schenck Woolman, (\$3.50, postage 20c).  
Sewing Tablets—Graded Sewing Texts with all Materials. Seven parts, by Margaret L. Blair, (\$.50 each, postage 8c each).  
School Garment Drafting, Jennie M. Haner, (\$1.00, postage 6c).  
Lessons in Garment Drafting, Mae Gingles, (\$.60, postage 6c).  
Progressive Lessons in Needlework, Catharine F. Johnson, (\$.90, postage 8c).  
Dressmaking Up-to-date, Butterick Pub. Co., (\$.25, postage 8c).  
When Mother Lets Us Sew, Virginia Ralston, (\$.75, postage 6c).  
The Art of Millinery, Anna Ben Yusuf, (\$2.00, postage 14c).  
Practical Millinery Lessons, Illustrated Milliner Co., (\$1.00, postage 8c).

## **TEST QUESTIONS**

The following questions constitute the "written recitation" which the regular members of the A. S. H. E. answer in writing and send in for the correction and comment of the instructor. They are intended to emphasize and fix in the memory the most important points in the lesson.

## **TEXTILES AND CLOTHING**

### **PART III**

---

**Read Carefully.** To make this test of greatest value to you, write fully from your personal standpoint and experience. Try as many methods given in the text as your time will allow so that you may ask for explanation if the descriptions are not clear to you. Methods are many; if you do not agree with these given, suggest better ones.

---

1. (a) What are the requisites for good dress-making? (b) How does dressmaking differ from white sewing in make, finish, and ornamentation?
2. From your point of view what do you consider a successful garment?
3. Give methods of altering patterns.
4. Give briefly the method of cutting and making from patterns; (a) a shirt waist, with cuff open opposite seam; (b) a woolen skirt, including method of stitching, pressing, and finishing.
5. How may pressing be done to give the best results? What garments require little or no pressing, and why?
6. (a) State some of the principles and purposes of ornament. (b) What is your idea of ornament applied to garments? (c) Give some errors in ornamentation not named in text.

7. Cut from magazines illustrations showing your idea of good and faulty ornamentation in dress. Give reason for your opinion.
8. Illustrate in some way, either by picture, drawing, embroidery, braid, or stitching, some design appropriate for ornament work on neck or sleeve.
9. Where should ornament be placed, and why?
10. (a) Give your idea of appropriate design on textiles. (b) The advantage and disadvantage of plain materials.
11. Make a color card of silk, wool, paper or raffia showing colors that contrast. (b) Colors that harmonize.
12. What colors do you find satisfactory for your own wear, and why?
13. What materials are best suited for infants' garments? (b) What can you say in regard to children's clothing?
14. What is your opinion of the care of clothing?  
(b) What experience have you had in cleaning (a) cotton, (b) wool, (c) linen, (d) silk, (e) velvet?
15. Do you consider it economy to repair garments? Can you suggest better methods than those given in the text?



16. If possible make some garment, shirt waist, skirt, or simple dress while studying this lesson and describe in detail how you went about it, the result, time taken, total cost. Tell why you selected the design, the color, the material.
17. Have you found the ready made garments satisfactory in underwear and dresses?
18. Tell of some of your failures in dressmaking and give the reasons for your lack of success.
19. What methods, new to you, have you tried in connection with this lesson? What questions have you to ask?
20. Can you add any suggestions that would be helpful to others in this work?
21. Wherein have the lessons been of practical value to you?
22. *For Teachers.* Draw up an outline for a course in sewing to combine two considerations: (a) adaptability to the child's interests and capacities, (b) orderly sequence in the technical part.

**Note:** After completing the answers, sign your full name.

**REFERENCES: ORNAMENT AND DESIGN**

- Bachelor—Principles of Design in America. (\$3.00.)  
Brown—History of Decorative Art. (\$1.25.)  
Carter, Mrs. H. J.—Historic Ornament in Color. (15c. a sheet). Prang.  
Clifford—Period Decoration. (\$3.00.)  
Crane—Claims of Decorative Art. (Out of print.)  
Crane—Line and Form. (\$2.25.)  
Daniels—Teaching of Ornament. (\$1.50.)  
Day—Application of Ornament. (\$1.25.)  
Day—Nature in Ornament. (\$4.00.)  
Day—Ornamental Design. (Out of print.)  
Day—Planning of Ornament. (Out of print.)  
Day—Decorative Design of all Ages. (\$0.40.)  
Day—Ornament and Its Application. (\$3.25.)  
Day—Ornamental Design, Anatomy of Pattern, Planning of Ornament. (\$3.00.)  
Day—Some Principles of Everyday Art. (Out of print.)  
Glazier—Manual of Historic Ornament. (New edition in press.)  
Hulme—Birth and Development of Ornament. (Out of print.)  
Jones—Grammar of Ornament. (\$18.00.)  
Prang—Art and Ornament in Egypt. (\$1.50.)  
*Note*—The books out of print may be found in some public libraries.

**REFERENCES: HISTORY OF COSTUME**

- Earle—Costume of Colonial Times. (\$1.25.)  
Earle—Two Centuries of Costume in America, 2 vols.  
(\$2.50 each.)  
Evans—Chapters on Greek Dress. (Out of print.)  
Fairholt—Costume of England, 2 vols. (\$1.50 each.)  
Hill—History of English Dress. (Out of print.)  
McClellan—Historic Dress in America. (\$10.00.)  
Planchet—History in British Costume. (\$1.50.)  
Quegly—What Dress Makes of Us. (\$1.25.)  
Racinet—Costume. (\$2.00.)  
Rhead—Chats on Costume. (\$1.50.)  
Schild—Old English Peasant Costume from Boadicea to  
Queen Victoria. (Out of print.)

**SUPPLEMENTARY PROGRAM  
ARRANGED FOR CLASS STUDY ON  
TEXTILES AND CLOTHING**

**MEETING I**

(Study pages 1-59)

**Primitive Methods**

Endeavor to obtain a Colonial spinning-wheel in working order, and get some one to operate it.

If possible, obtain samples of weaving done on a hand loom.

Examine a hand-loom if possible. They may be seen at the manufacturers of rag and remade carpets.

*References:* Woman's Share in Primitive Culture, Mason, Chapter III, The Weaver. (\$1.75, postage 16c.)

Colonial Days in Old New England, by Earle.  
(\$1.25, postage 12c.)

**Textile Fibres**

Collect an exhibit of raw fibres and fibres in process of manufacture. Send to the U. S. Department of Agriculture, Department of Botany, Washington, D. C., for small samples; to manufacturers of thread; to friends in manufacturing towns.

Test the various fibres by burning. Examine under a microscope with a small hand-glass, if greater power cannot be obtained. Try warm acid—sulphuric, hydrochloric, or oxalic—on the fibres; let the fibres dry. Also try a solution of caustic soda on the fibres.

*References:* The Textile Fibres, by Matthews. (\$3.50, postage 16c.)

Textile Fibres and Cotton Fibre, pamphlets of  
the American School of Correspondence.  
(50c. each, postage 4c. each.)

Send for all the Government Bulletins mentioned in the Bibliography, page 104. Note that the *free* bulletins are obtained simply by addressing the Department of Agriculture, Washington, D. C., but the *sale* bulletins only by sending coin or money order to the Superintendent of Documents, Washington, D. C.

## MEETING II

(Study pages 59-102)

### Modern Methods

Visit a textile mill if possible, after studying the text.

Practice home dyeing. Read carefully the directions given by the manufacturers of the dyes. See the booklet "Diamond Dyes," to be obtained at many drug stores, or send for it to Wells Richardson, Burlington, Vermont.

*References:* Text-books of the American School of Correspondence — especially Textile Chemistry and Dyeing. (Parts I, II, III, and IV, postage 4c. each.)

The Dyeing of Textile Fabrics, by Hummell. (\$1.75, postage 12c.)

Bleaching and Calico Printing (containing samples), by Duerr. (\$4.00, postage 14c.)

### Weaves and Fabrics

Show as many different kinds of weaves as possible. Separate the threads and examine under a hand microscope.

Get the local dry-goods or department store to co-operate with you in getting up an exhibit of samples of standard goods—cotton, woolen, worsted, linen, and silk. Label each sample with the width and price.

Test some of the samples of wash goods for fastness to washing and light, by washing in warm water and soap (or boiling in the soap and water) and expose to sunlight all day for three or four days. *Keep a part of each sample for comparison.*

(Select a composite set of answers to the Test Questions on Part I and send to the School, with report on the supplemental work done and Meetings I and II.)

### MEETING III

(Study pages 107-123)

#### **Sewing: Plain Stitches**

Send to manufacturers for samples showing the process of manufacture of pins, needles, etc.

Demonstrate different ways of making the same stitches; discuss best methods.

#### **Embroidery**

Show how all the embroidery stitches are made.

Get up an exhibit of all kinds of embroidery, including Oriental, Japanese, old samplers, etc.

Have members make Model I, First Series.

*References:* Home and School Sewing, by Patton. (\$0.60, postage 6c.)

• School Needlework, by Hapgood. (\$0.75, postage 6c.)

Manual of Exercise in Hand Sewing, by Blair. (\$1.25, postage 10c.)

*Topic:* Educational Value of Sewing in the Public Schools.

Methods. See "A Sewing Course," by Mary S. Woolman, Introduction (\$3.50, postage 20c.), and "The Teaching of Domestic Science in the United States of America," by Alice Ravenhill, pages 9-10, 43-46. (\$0.75, postage 12c.)

**MEETING IV**

(Study pages 123-165)

**Hems, Seams, Fastenings, Darning, Patching**

Have all members make models II, III, IV, and V.

Previously assign members to furnish models or examples of all other hems, seams, fastenings, patches, darns, etc., illustrated or described in the text, and as many more as possible.

**Machine Sewing**

Get the local sewing machine agent to give a demonstration of the workings of the attachments of the machine.

(Select models and answers to Test Questions on Part II and send them to the School, with a report of Meetings III and IV.)

**MEETING V**

(Study pages 167-200)

**Dressmaking**

Get the local dry-goods or department store to lend different kinds of dress forms.

Collect patterns from different makers.

Show how patterns are altered to suit the figure. (See text and "Dressmaking Up to Date.")

As many as possible cut out and begin making a simple shirt-waist or skirt. Show finished garment at next meeting, giving accurate account of cost and time spent.

*References:* Dressmaking Up to Date, The Butterick Co. (\$0.25, postage 8c.)

Sewing and Garment Drafting, by Margaret L. Blair. (\$1.25, postage 12c.)

**MEETING VI**

(Study pages 205-228)

**Construction and Ornament in Dress; Color**

Collect illustrations showing good and faulty ornamentation. Procure samples of fabrics showing good and faulty ornamentation.

Make a color card showing contrast and harmony of color.

(See Question 11.)

*References:* See list on pages 234 and 235.

**Children's Clothing**

Get up an exhibit of simple and satisfactory clothing for children, including color, material, style and make.

Discuss children's clothes in reference to laundering.

**Care and Repair of Clothes**

Show examples of successful repairing.

Try some of the methods of cleaning. (See, also *Chemistry of the Household* pages 73-84.)

(Select answers to Test Questions on Part III and send them to the School, with report on Meetings V and VI.)



## INDEX

- Adulteration of linen, 87  
Alpaca, 90  
Altering sleeve patterns, 194  
Angora wool, 39  
Aniline dyes, 79  
Arrow heads, 123  
Aack stitch, 112
- Basting, 108  
Bibliography, 103, 229  
Bleaching, 78  
Bobbin, 19  
Boning waist, 192  
Bow, the, 208  
Burling, 83  
Bust form, 168  
Button holes, 141  
    large, 145  
    making, 144  
Buttons, sewing on, 145
- Carding, 59  
Care of clothing, 219  
Cassimere twills, 73, 75  
Cat stitch, 116  
Catch stitch, 116  
Chain stitch, 116  
Checks, 213  
Children's clothes, 216, 217  
Cleaning, 59, 221  
Collars, 198  
    putting on, 199  
Color in dress, 214  
Colors, mordant, 79  
Combing, 60  
Conventional designs, 213  
Costumes, references, 234  
Cotton, 29  
    boles, 32  
    fibers, 34
- Cotton goods, 85  
    home of, 30  
    Nankin, 34  
    sea island, 30  
    upland, 30  
Cross stitch, 120  
Cuffs, 196  
Cutting table, 168
- Darning, 155  
    on machine, 158  
    over net 157  
Decorations, placing, 208  
Distaff, 12  
Double cloth, 77  
Draped waist, 192  
Drawing tapes, 140  
Dressmaking, 167  
Dyeing, 78  
    home, 80  
Dyes, aniline, 79  
Dyestuffs, natural, 80
- Embroidery, 204  
    as ornament, 204  
    eyelet, 122  
    shadow, 123  
    stitches, 114  
Extension hem, 227  
Eyelet embroidery, 122  
Eyelets, 149
- Fabrics, 85  
    list of, 96-102  
    names of, 94  
    primitive, 27  
    width of, 93  
Facing, bias, 141  
    skirt, 179  
Fastening the thread, 109  
Fastenings, 141

- Feather stitch, 118
- Fibers, 29
  - cotton, 29
  - flax, 43
  - silk, 53
  - wool, 37
- Finishes, 139
- Finishing skirt, 179
  - seams, 196
  - waist, 192
- Finishing, woolens, 83
- Fitting, 173, 193
  - sleeves, 190
  - waists, 190
- Flax, 43
  - fibers, 47
  - hackling, 44, 47
- Flocks, 83
- Folding garments, 220
- French hem, 127
  - knots, 119
  - seam, 131
- Fulling, 83
- Fur, 40
- Gathering, 111, 138
- Gathers, whipped, 127
- Gauging, 112
- Gigging, 83
- Gingham, 86
- Grease spots, 122
- Hand sewing, 107
- Harmony in dress, 215
- Harness, the, 70
- Heddle, 17
- Hemp, 50
- Hem stitch, 118
- Hems, 123
  - bias, 124
  - faced, 124
  - flannel, 127
  - French, 127
  - folding, 123
- Hems, rolled, 126
- Herringbone stitch, 116
- Home dyeing, 80
- Hook and eyes, 147
- Hydroscopic moisture, 42
- Jacquard loom, 70
- Joining lace, 160
- Jute, 50
- Knit goods, 72
- Lace, design of, 208
- Laces, use of, 207
- Laundering, 225
- Lengthening garments, 226
- Linen, 86
  - adulteration of, 87
  - characteristics of, 47
- Lining, cutting, 188
- Loading silk, 56
- Looms, 17
  - Colonial, 19, 21, 22
  - development of, 19
  - diagram of, 23
  - fly shuttle, 26
  - four harness, hand, 21
  - Jacquard, 70
  - Japanese, 20
  - modern, 25, 69
  - Navajo, 18
  - Swedish hand, 24
- Loop stitch, 116
- Madder bleach, 78
- Machine darning, 158
  - sewing, 162
- Mending, 83, 225
- Mitering embroidery, 158
- Modern methods, 59
- Mohair, 90
- Mordant colors, 79
- Muslin, 85
- Nankin cotton, 34
- Natural dyestuffs, 80

- Olona, 53  
Ornament, 203  
  embroidery as, 204  
  fitness of, 209  
  flowers as, 205  
  of textiles, 212  
Ornamental stitches, 108, 114  
Ornamentation, errors in, 204  
Outline stitch, 114  
Overcasting, 114, 142  
Oversewing, 113  
  
Packing clothing, 220  
Passementerie, 206  
Patching, 149  
Patterns, 171  
  altering, 173  
  cloth, 174  
  lengthening, 173  
  pinning, 176  
  placing, 176  
  selection of, 171  
  testing, 174  
  use of, 172  
Picking, 59  
Piled fabrics, 91  
Plackets, 135  
  faced, 137  
Plaids, 213  
Plain material, 212  
Plush, 77  
Pressing, 201  
  board, 168, 201  
  wet, 202  
Primitive methods, 3  
Printing, 81  
  block, 81  
  machine, 81  
  warps, 82  
  
Ramie, 50  
Raw silk, 56  
Reed, 19  
Reeling silk, 54  
  
Repairing, 225  
Retting flax, 45  
Roving, 61  
Running stitch, 110  
  
Sateen weave, 79  
Satin, 91  
  stitch, 121  
Scouring agents, 41  
Sea island cotton, 30  
Seams, 128  
  beaded, 131  
  felled, 128  
  flannel, 135  
  French, 131  
  lapped, 133  
  slot, 131  
Serges, 88  
Seven-gored skirt, 172  
Sewing, hand, 107  
  machine, 162  
Sewing machines, 162  
  care of, 162  
  types of, 162  
  use of, 164  
Shadow embroidery, 123  
Sheep, 39  
Shirt waists, cutting, 182  
  plan for making, 183  
Shuttle, 19  
Silk, 53  
  artificial, 58  
  boiling off, 56  
  fiber, 53  
  loading, 56, 90  
  production, 53  
  raw, 56  
  twilled, 91  
Silk, wash, 91  
Silk worm, 54  
Silks, 90  
Singeing, 78  
Skirt, 172  
  band, 179